



NATIONAL
LABORATORY
OF THE ROCKIES

Model Specification for the Generic Model of DFIG-based Adjustable Speed (Type 3) Pumped Storage Hydropower Storage Technology

Jin Tan, Zaid Ibn Mahmood
National Laboratory of the Rockies
05.08.2026

For WECC Model Validation Subcommittee Meeting

Contents

- 1** Motivation
- 2** Background
- 3** AS-PSH (Type 3) Structure Overview
- 4** Sub-blocks of a AS-PSH (Type 3) Unit
- 5** Input and Output Channels and Parameters
- 6** Model Simulation and Validation
- 7** Summary

Motivation: PSH project development pipeline in the United States has seen a boom in recent years

U.S. Pumped Storage Hydropower Development Pipeline, 2025

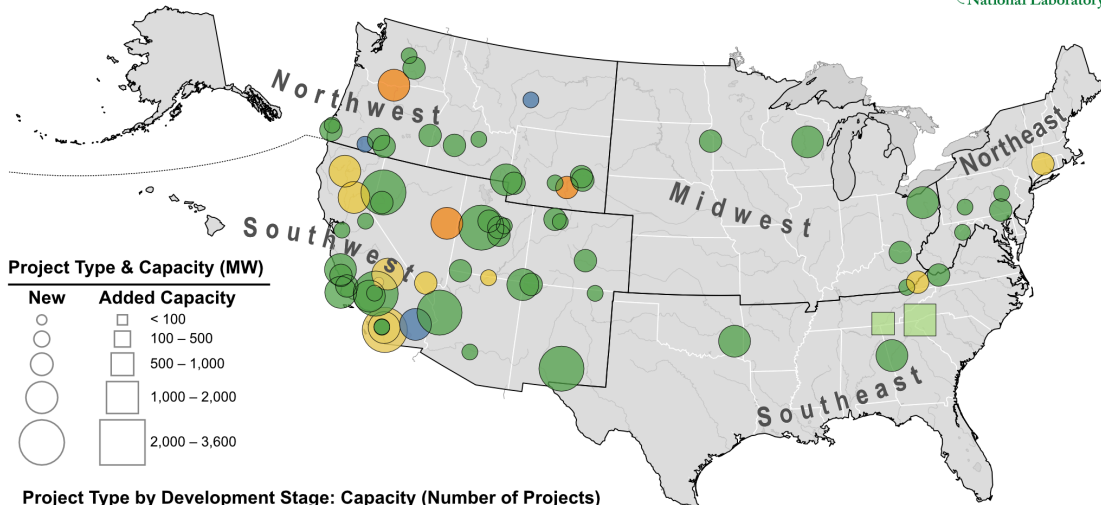

Project Type by Development Stage: Capacity (Number of Projects)

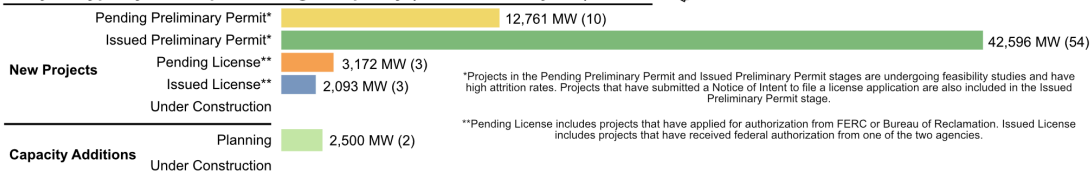

Map Source: Erik H. Schmidt, Megan M. Johnson and Rocío Urija-Martínez. 2025. U.S. Pumped Storage Hydropower Development Pipeline, 2025. [Map]. HydroSource, Oak Ridge National Laboratory, Oak Ridge, Tennessee, USA. DOI: 10.21951/HMR_PipelineMaps/2569210

Data Source: Johnson, M.M. and Urija-Martínez, R. (2025). U.S. Hydropower Development Pipeline Data, 2025. HydroSource, Oak Ridge National Laboratory, Oak Ridge, Tennessee, USA. DOI: 10.21951/HMR_PipelineFY25/2563167

Pumped Storage Hydropower (PSH)

- Global: 321 plants totaling approximately **196 GW** (Global Energy Monitor, 2026)
- USA: 43 plants with combined capacity of approximately **22 GW** (Koritarov et al., 2022)

Adjustable-Speed PSH (AS-PSH)

- Global: approximately **75% of European PSH capacity** (CORDIS, 2016)
- USA: most of the **55 GW** of new (2021) PSH projects in development are expected to be **AS-PSH** (National Hydropower Association, 2021)

Background: AS-PSH (Type 3) Adaptations

- Most of the AS-PSH (Type 3) plants are in Asia and Europe.
- No AS-PSH (Type 3) plant is operational yet in USA.

Table 1: Worldwide Type 3 AS-PSH projects.

Plant	Capacity (MW)	Country	Commissioning Year/ Status	Manufacturer / Supplier	Ref.
Goldisthal PSP	1060	Germany	2004	ANDRITZ	Vasudevan et al. (2021)
Yagisawa PSP	240	Japan	1990	Toshiba	Vasudevan et al. (2021)
Fengning PSP	600	China	Ongoing	ANDRITZ	Guo et al. (2025)
Tai'an PSP	600	China	Ongoing	Dongfang Electric Corporation	Guo et al. (2025)
Zhongdong PSP	400	China	Ongoing	Haebin Electric Corporation	Guo et al. (2025)
Langjiang PSP	300	China	Ongoing	Dongfang Electric Corporation	Guo et al. (2025)
XFLEX HYDRO	780	Portugal	2017	Voith, ANDRITZ, General Electric	XFLEX HYDRO
Linth-Limmern PSP	1000	Switzerland	2016	General Electric, ABB	ABB
Avče PSP	185	Slovenia	2009	Rudis	Bidgoli et al. (2020)

Motivation: Advantages of AS-PSH

- **Advantages**

- **Grid Service:** frequency regulation services in both generating and pumping, an advantage not available in fixed-speed units (Shao et al., 2021)
- **Disturbance Response:** faster dynamic response during grid disturbances, less frequency drop following outages (Koritarov et al., 2022)
- **Equipment Longevity:** Less wear and tear, resulting in longer service life (Muljadi et al., 2021)
- **Design and Site Flexibility:** Efficient over a wide head range, allowing smaller-area reservoirs
- **Starting and Transition Capability:** Inherent self-starting in pumping mode, auxiliary starting motors not required and less downtime between operating modes

- **Disadvantages**

- Higher capital cost due to converters
- Advanced controls required

Background: Types of Pumped Storage Hydro Technologies

Pumped Storage Power Plant

Fixed Speed

Hybrid

Variable Speed

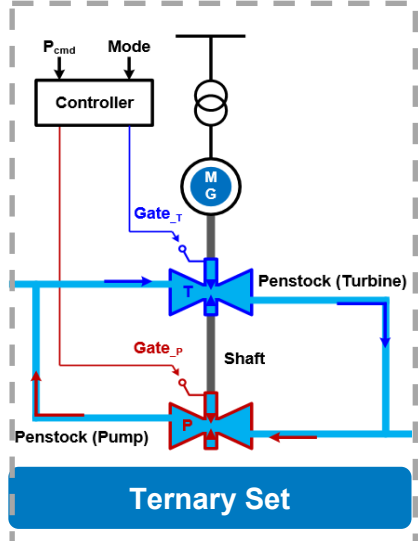
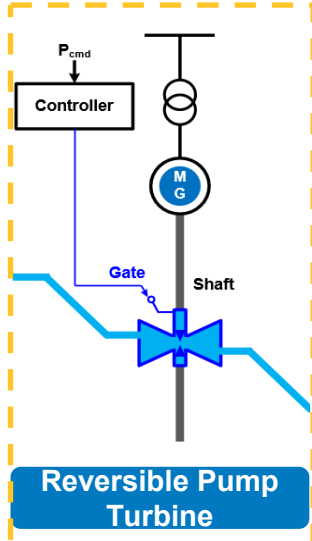

Specification Approved

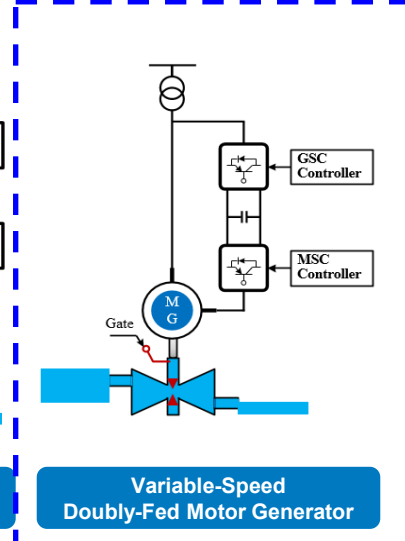
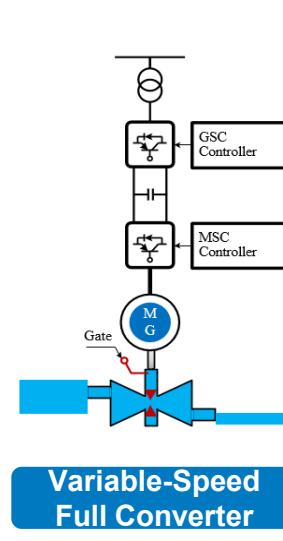
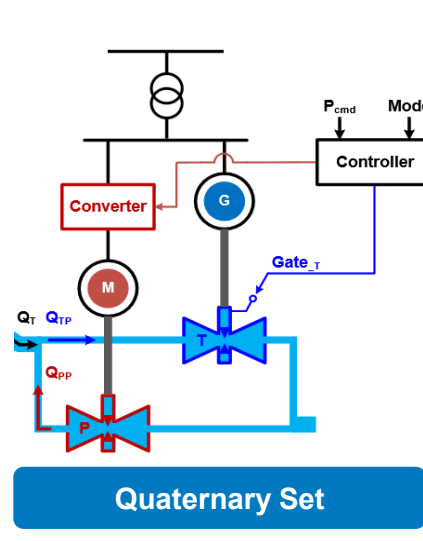

Current Effort

Background: AS-PSH (Type 3)

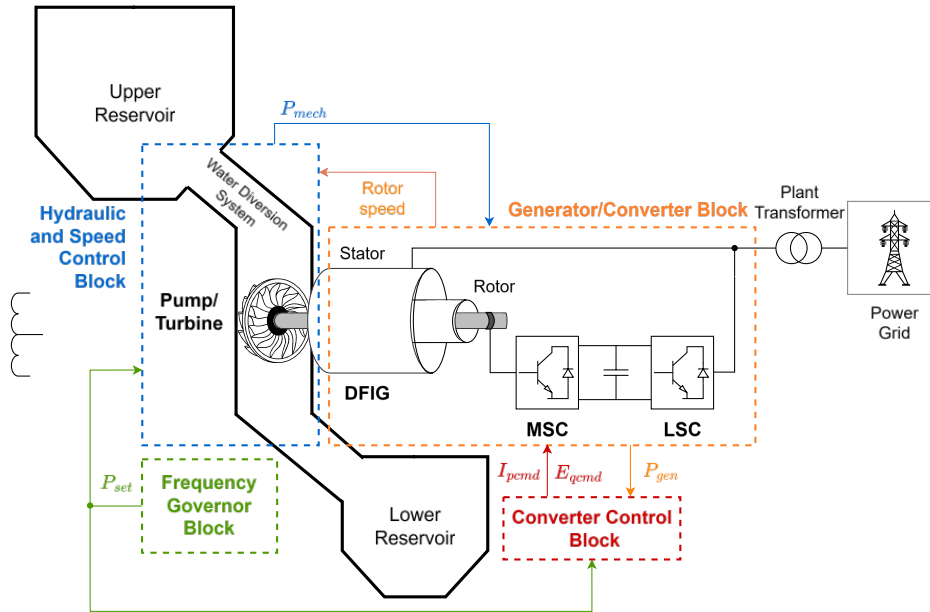

- **Advantages/Disadvantages of AS-PSH (Type 3)**
 - **Smaller converter:** 10–30 % of rated power flows through the converter for standard ± 10 –30 % speed range; **low converter rating, saving cost.**
 - **Lower losses:** small fraction of power through converter; **reduced converter losses and higher efficiency.**
 - **Narrower speed range:** speed variation is only ± 5 –10 %, while Type 4 can sustain rated torque across the full 0–100 % range.

AS-PSH (Type 3) Structure Overview

- A user-defined model (UDM) of AS-PSH (Type 3) has been developed in PSS/E.

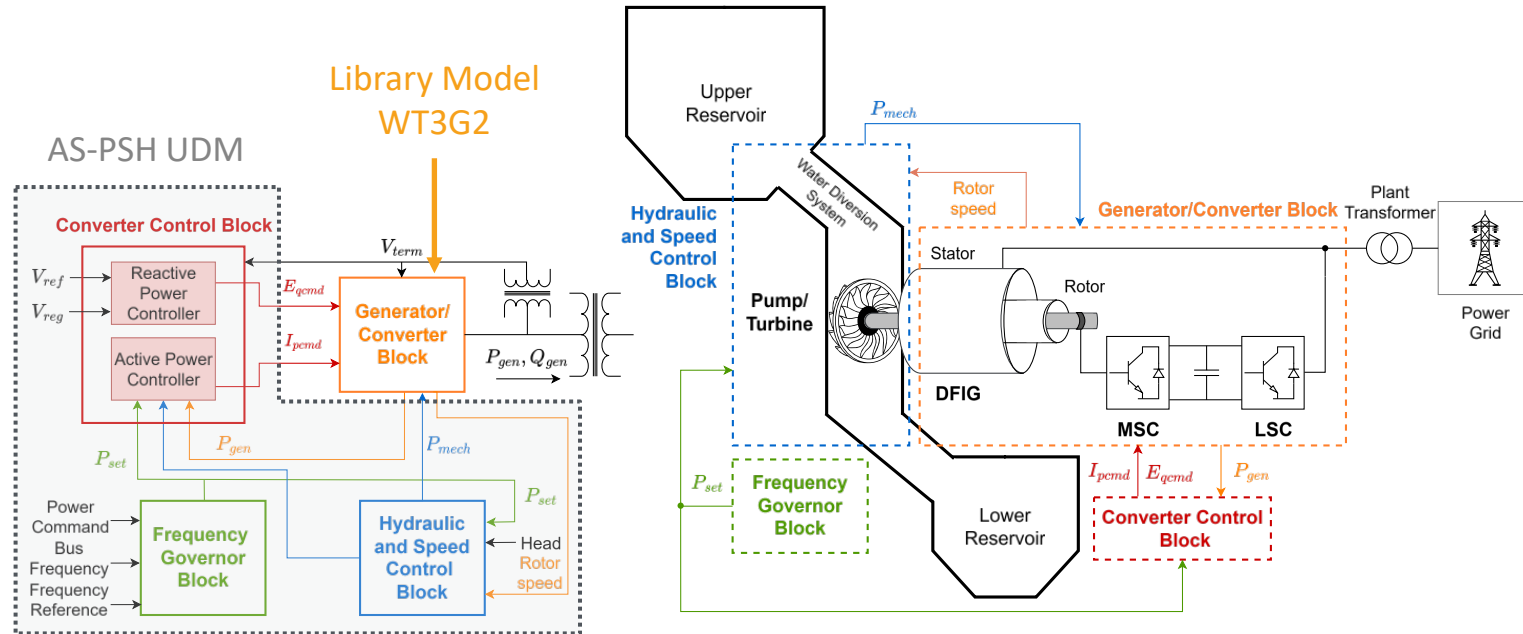

Figure 2: AS-PSH UDM connectivity diagram (left) and mapping onto physical and control components (right).

Sub-blocks of a AS-PSH (Type 3) Unit

- A unified UDM supporting both turbine and pump modes is developed.
- The model has been implemented and integrated into PSS/E.
- The UDM is validated against existing references.
- It can model up to 4 AS-PSH units with a **shared penstock**.

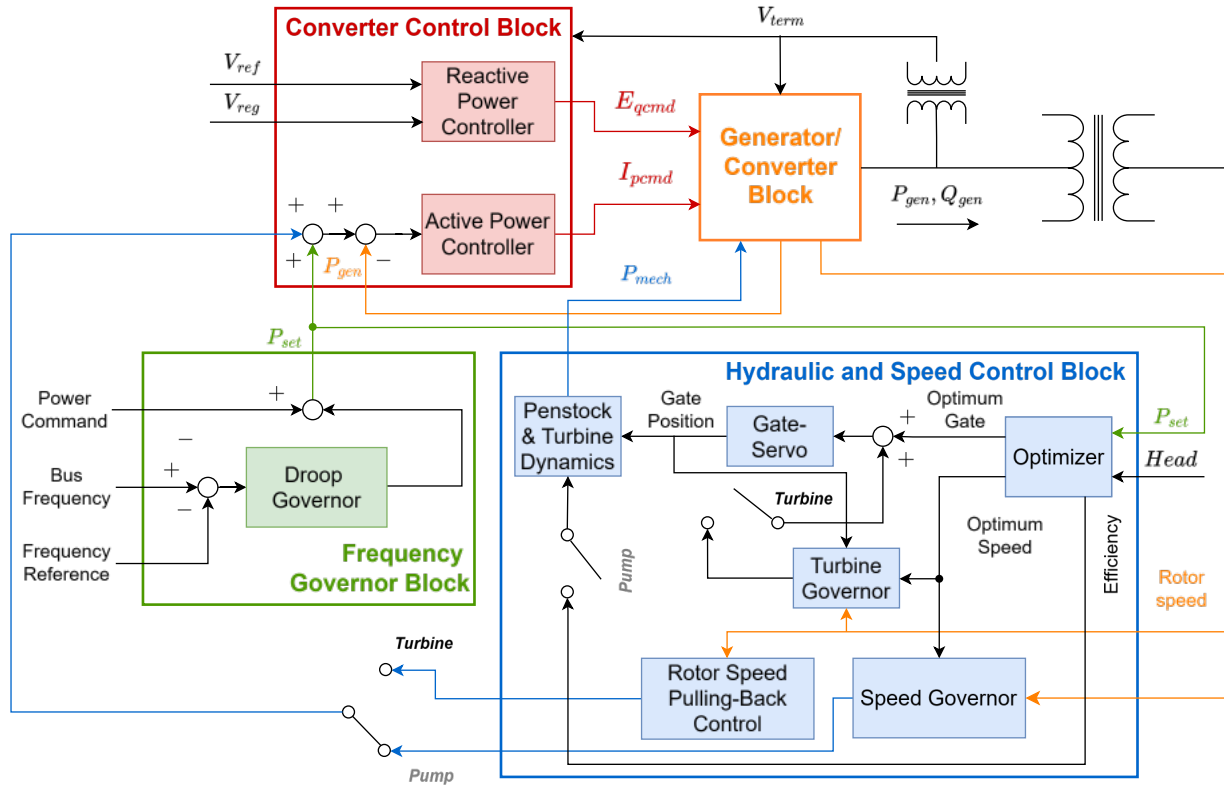

Figure 3: Sub-blocks of Type 3 AS-PSH UDM

Turbine vs Pump Mode

- Governor / Gate Control:** In turbine mode, the **turbine governor** actively adjusts the gate to regulate speed. In pump mode, the governor is inactive, and the gate tracks the optimum gate reference.
- Speed Control:** In turbine mode, rotor speed is kept within limits by the **rotor speed pulling-back control**. In pump mode, rotor speed is regulated to an optimal reference using a proportional integral (PI) **speed governor**.
- Efficiency Modeling:** In pump mode, both head and efficiency vary with operating point.

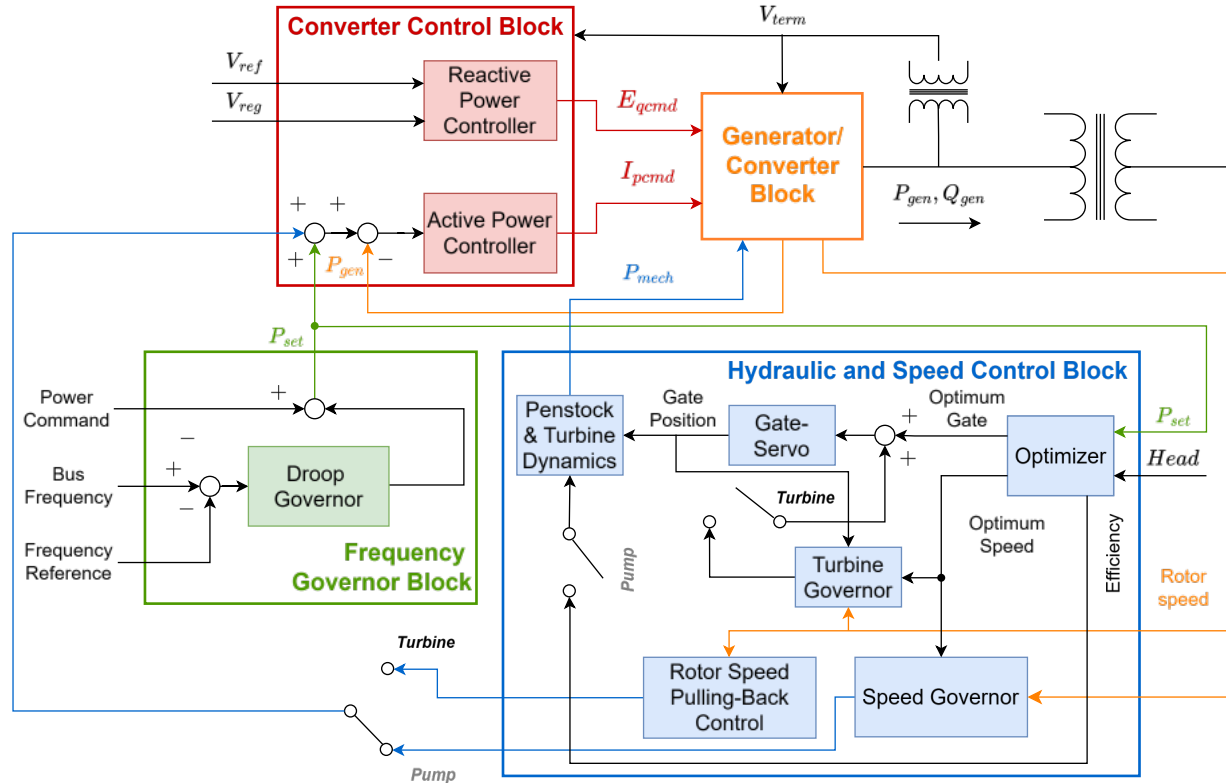

Figure 3: Sub-blocks of Type 3 AS-PSH UDM

Hydraulic and Speed Control Block

- A proportional-integral-derivative (PID) **turbine governor** is active in the turbine mode to regulate rotor speed.
- The **optimizer** takes inputs P_{set} and **Head, H_0** , and outputs **Optimum Gate** and **Optimum Speed** (also efficiency in pump mode).
- The **gate-servo** tracks the Optimum Gate reference, while the turbine governor adds a speed-error correction component in the turbine mode.
- A shared penstock with 4 waterways is modelled for both modes (Koritarov et al., 2013).

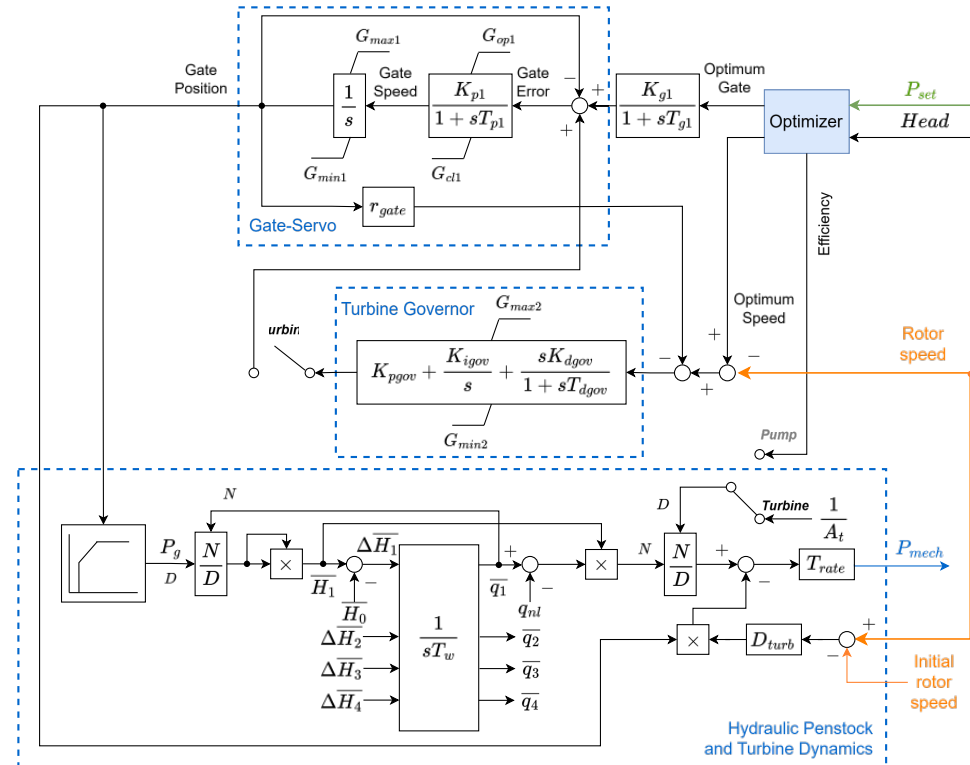

Figure 4: Turbine-Governor and Penstock Dynamics

Hydraulic and Speed Control Block (cont'd)

- **Rotor-speed pull-back control**

- Active in turbine mode.
- Limits power when rotor speed exceeds predefined thresholds to prevent overspeed/under speed. Output is sent to the active power controller.

- **Speed governor**

- Active in pump mode.
- Regulates rotor speed by acting on the speed deviation from its reference. Output is also sent to active power controller

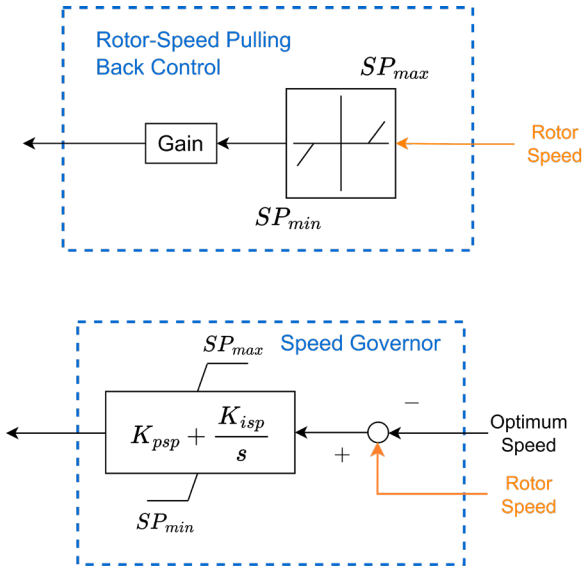

Figure 5: Rotor-speed Pulling back control (top) and Pump-mode speed governor (bottom)

Bus Frequency Governor Block

- The frequency governor takes as input the measured bus frequency f , the reference f_{ref} and the external power command P_{cmd} to generate the power reference P_{set} .
- The frequency signal is filtered, passed through a deadband, and shaped before control action.
- A droop-based control produces a power correction, which is added to the power command to generate P_{set} .

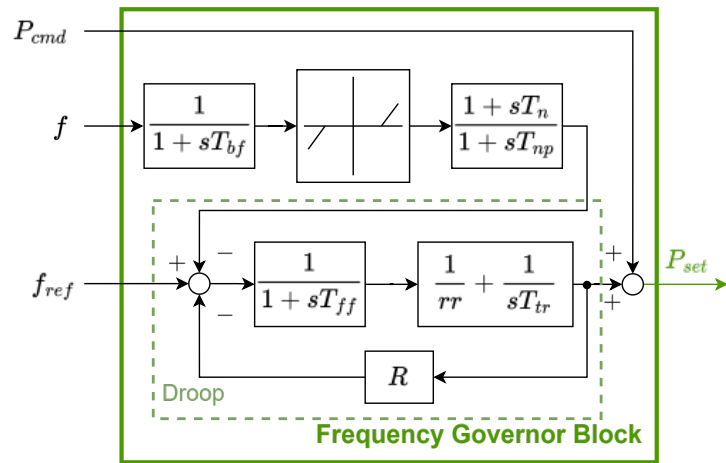

Figure 6: Frequency Governor Block

Converter Control Block

- Reactive Power Controller

- Filters regulated-bus voltage V_{reg} and compares it to V_{ref} to form the voltage error.
- A PI regulator with limits and first-order shaping produces E_{qcmd} .

Active Power Controller

- Filters P_{gen} , applies the mode-dependent correction, and compares to P_{set} to form the power error.
- A PI regulator with limits, rate limits, and first-order shaping produces P_{ord} , which is converted to I_{pcmd} .

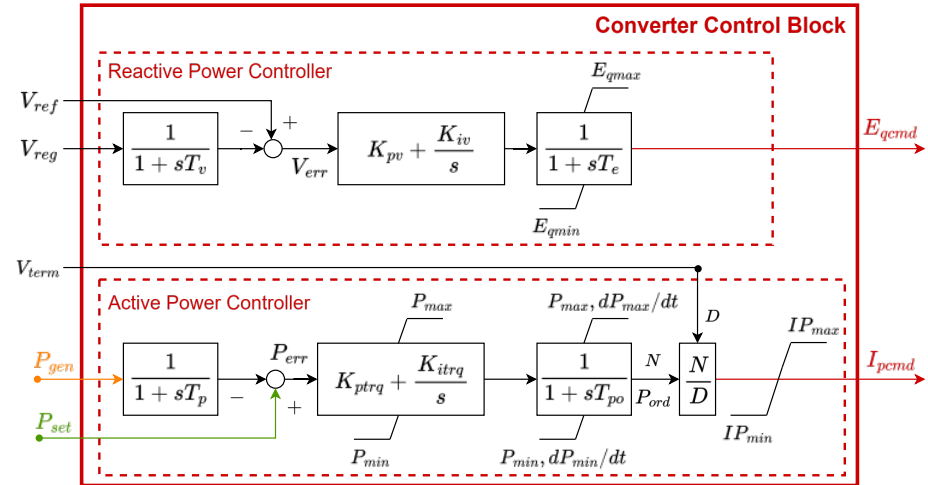

Figure 7: Converter Control Block

Generator/Converter Block

- Generator/converter model follows the standard **WECC DFIG (Type 3) WT3G2 structure**, including current control, PI regulation, LVPL/LVRT logic, and current limits.
- A potential improvement is suggested to the high-voltage reactive current based on an overvoltage compensation gain.

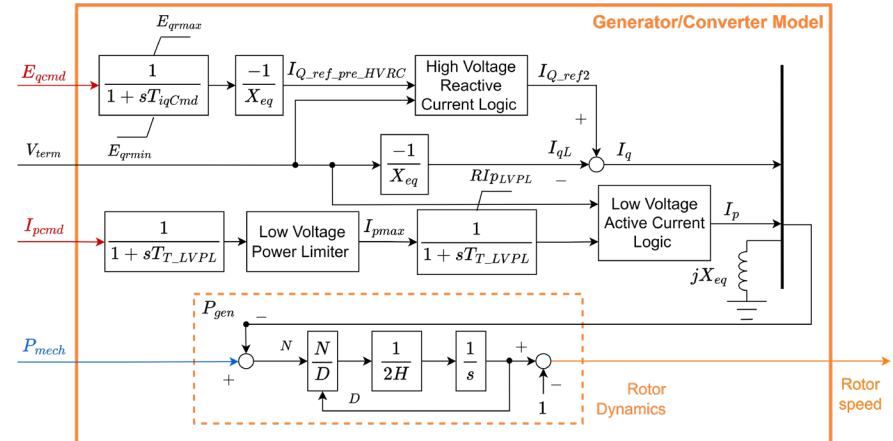

Figure 8: Generator/Converter Block

Input and Output Channels

Input Channel

Channel	Symbol	Description
IC0	P_{cmd}	Active-power command/reference for the plant, p.u.
IC1	P_{gen}	Measured electrical active power feedback, p.u.
IC2	Δf	Frequency deviation at the machine bus, p.u.
IC3	V_{ref}	Voltage reference for the reactive-power controller, p.u.
IC4	V_{reg}	Regulated voltage magnitude used by the voltage-control loop, p.u.
IC5	V_{term}	Terminal voltage magnitude used in the current-command calculation, p.u.

Output Channel

Channel	Symbol	Description
OC0	E_{qcmd}	Reactive-voltage command to the converter control block, p.u.
OC1	I_{pcmd}	Active-current command to the generator/converter block, p.u.
OC2	P_{mech}	Mechanical power output from the hydraulic-speed block, p.u.
OC3	\bar{G}	Physical gate position after servo limits, p.u.
OC4	ω	Rotor speed, p.u.
OC5	P_{set}	Internal active-power reference after frequency governor shaping, p.u.
OC6	q_{net}	Net water-flow signal used in the hydraulic power calculation, p.u.

Parameters

CON	Description	Units	Turbine Mode Example	Pump Mode Example
Tbf	Bus-frequency measurement filter time constant	s	0.02	0.02
DB	Symmetric deadband	p.u.	0.00	0.005
Tn	Shaping numerator time constant	s	1.00	1.00
Tnp	Shaping denominator time constant	s	1.00	1.00
Tff	Filter time constant	s	0.02	0.02
rr	Frequency-loop gain term	p.u.	1.00	0.25
Tr	Frequency-loop integrator time constant	s	1.00	0.50
R	Droop parameter	p.u.	0.03	0.00
Tbf	Bus-frequency measurement filter time constant	s	0.02	0.02
DB	Symmetric deadband	p.u.	0.00	0.005
H	Inertia constant	s	4.00	4.00
SPmin	Minimum speed-pullback threshold	p.u.	-0.50	-0.50
SPmax	Maximum speed-pullback threshold	p.u.	0.50	0.50
Klim	Pulling-back gain	—	40	N/A

Parameters (cont'd)

CON	Description	Units	Turbine Mode Example	Pump Mode Example
Kg1	Gate-reference feedforward gain	—	1.00	1.00
Tg1	Gate-reference feedforward time constant	s	0.50	0.50
Kp1	Gate-servo gain	—	10.00	10.00
Tp1	Gate-servo time constant	s	0.100	0.100
Kpgov	Governor proportional gain	—	3.00	N/A
Kigov	Governor integral gain	1/s	0.20	N/A
Kdgo	Governor derivative gain	s	0.00	N/A
Tdgo	Governor derivative time constant	s	0.10	N/A
Gmin1	Minimum gate-position limit	p.u.	0.00	0.00
Gmax1	Maximum gate-position limit	p.u.	1.00	1.00
Gmin2	Minimum governor-integrator limit	p.u.	0.00	0.00
Gmax2	Maximum governor-integrator limit	p.u.	1.02	1.02
rgate	Gate feedback coefficient	—	0.00	0.00
Dturb	Damping coefficient	p.u.	0.50	0.50

Parameters (cont'd)

CON	Description	Units	Turbine Mode Example	Pump Mode Example
At	Turbine hydraulic gain constant	—	1.20	1.20
Trate	Machine power rating	p.u.	1.00	1.00
H0	Nominal steady-state head	p.u.	1.00	1.00
Kpsp	Pump speed-control proportional gain	—	N/A	5.00
Kisp	Pump speed-control integral gain	1/s	N/A	5.00
qnl	No-load flow	p.u.	0.08	-0.08
VOP1	Maximum gate opening rate	p.u./s	2.00	2.00
VCL1	Maximum gate closing rate	p.u./s	-2.00	-2.00
Tw	Equivalent water time constant	s	1.72	-1.17
A0	Pump head characteristic coefficient	—	N/A	1.1740
B0	Pump head characteristic coefficient	—	N/A	-0.0666
C0	Pump head characteristic coefficient	—	N/A	-0.3540
Tw11	Hydraulic coupling matrix element	s	0.84	0.84
Tw12	Hydraulic coupling matrix element	s	0.52	0.52

Parameters (cont'd)

CON	Description	Units	Turbine Mode Example	Pump Mode Example
Tw13	Hydraulic coupling matrix element	s	0.52	0.52
Tw14	Hydraulic coupling matrix element	s	0.52	0.52
Tw21	Hydraulic coupling matrix element	s	0.52	0.52
Tw22	Hydraulic coupling matrix element	s	0.84	0.84
Tw23	Hydraulic coupling matrix element	s	0.52	0.52
Tw24	Hydraulic coupling matrix element	s	0.52	0.52
Tw31	Hydraulic coupling matrix element	s	0.52	0.52
Tw32	Hydraulic coupling matrix element	s	0.52	0.52
Tw33	Hydraulic coupling matrix element	s	0.84	0.84
Tw34	Hydraulic coupling matrix element	s	0.52	0.52
Tw41	Hydraulic coupling matrix element	s	0.52	0.52
Tw42	Hydraulic coupling matrix element	s	0.52	0.52
Tw43	Hydraulic coupling matrix element	s	0.52	0.52
Tw44	Hydraulic coupling matrix element	s	0.84	0.84

Parameters (cont'd)

CON	Description	Units	Turbine Mode Example	Pump Mode Example
Tv	Voltage measurement filter time constant	s	0.2	0.2
Kpv	Voltage-loop proportional gain	—	1.00	1.00
Kiv	Voltage-loop integral gain	1/s	1.00	1.00
Te	Reactive-voltage-command filter time constant	s	0.2	0.2
Tp	Active-power measurement filter time constant	s	0.02	0.02
Kptrq	Active-power-loop proportional gain	—	1.00	1.00
Kitrq	Active-power-loop integral gain	1/s	1.00	1.00
Tpo	Active-power order filter time constant	s	0.02	0.02
Pmin	Minimum active-power command	p.u.	-1.00	-1.00
Pmax	Maximum active-power command	p.u.	1.00	1.00
dPmin	Minimum active-power rate limit	p.u./s	-10.00	-10.00
dPmax	Maximum active-power rate limit	p.u./s	10.00	10.00
IPmin	Minimum active-current command limit	p.u.	-1.20	-1.20
IPmax	Maximum active-current command limit	p.u.	1.20	1.20
Eqmin	Minimum reactive-voltage command limit	p.u.	0.90	0.70
Eqmax	Maximum reactive-voltage command limit	p.u.	1.10	1.30

Test Cases

Test system: 3-generator 10-bus small system

In this system, there are three voltage levels, 24 kV, 34.5 kV and 230 kV. The test AS-PSH unit is placed on Bus 19; a gas turbine and a C-PSH unit are placed on Bus 20 and Bus 15.

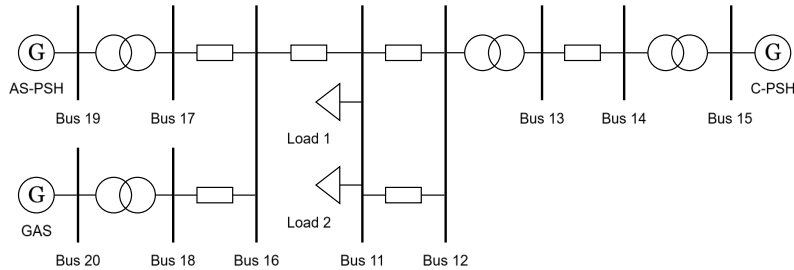

Figure 9: 3-Gen 10-Bus Test System

Test events:

1. Turbine Mode Operation
 - a. Generator Trip
 - b. Three-phase Fault
2. Pump Mode Operation
 - a. Load Trip
 - b. Three-phase Fault

Bus	Components	Generating Mode Case	Pumping Mode Case
Bus 15 C-PSH	GENSAE IEEEX1 HYGOV	28.9 MVA	
Bus 19 AS-PSH	PSH_UDM	1176 MVA	1276 MVA
Bus 20 Gas	GENROU	200 MVA	2400 MVA

Table 2: Details of system dynamic model components

Turbine Mode: Generator Trip

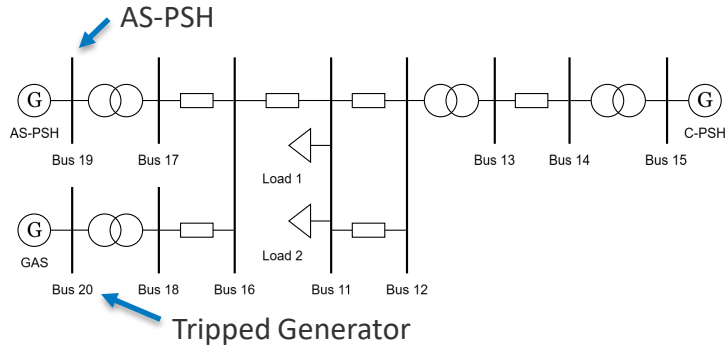

Figure 10: Generator trip in 10-Bus Test System.

Test Condition:

- The AS-PSH is an 1176 MVA machine at bus 19.
- At $t = 1$ s, the 200 MVA conventional gas generator at bus 20 is disconnected.

Observation:

- P_e and mechanical power P_m rises to meet the deficit.
- System reaches steady-state within ~ 20 s, with a slightly lower frequency than 60 Hz.

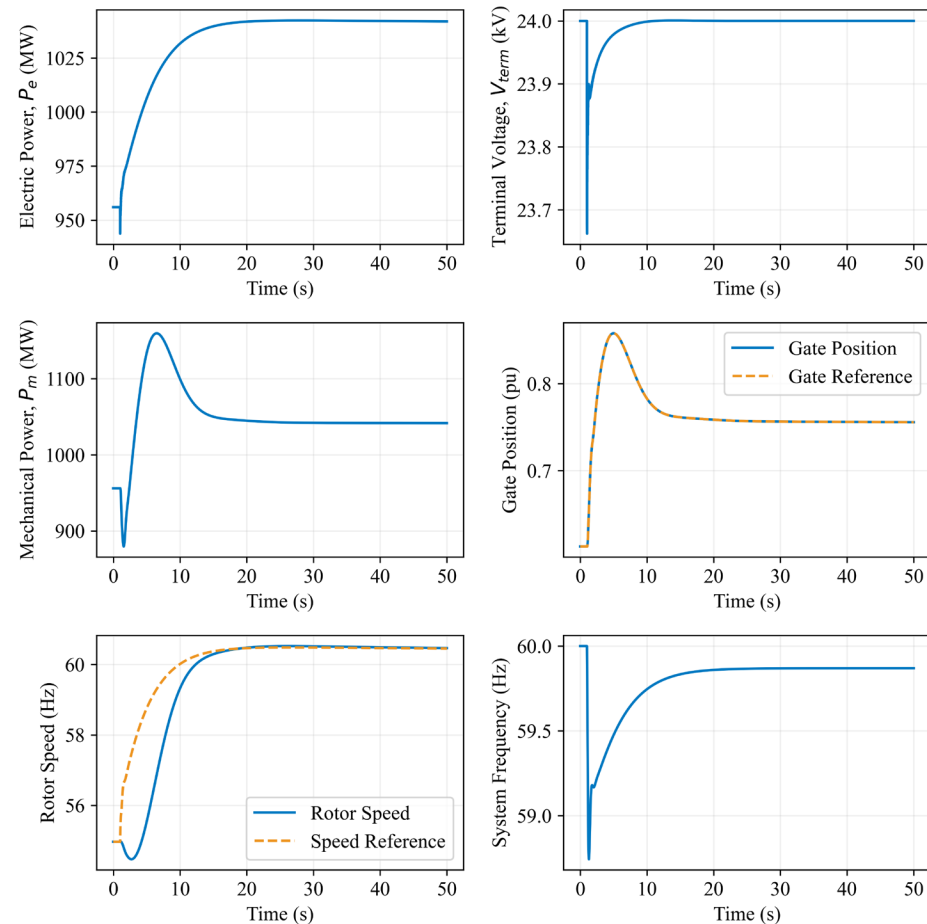

Figure 11: Time-domain simulation results of AS-PSH (Turbine Mode) from a generator trip event.

Turbine Mode: Three Phase Fault

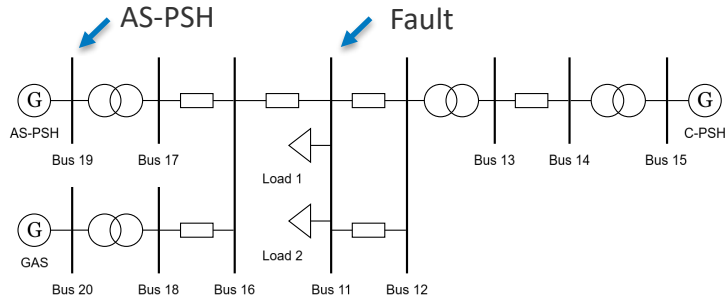

Figure 12: Three Phase Fault in 10-Bus Test System.

Test Condition:

- The AS-PSH is an 1176 MVA machine at bus 19.
- At $t = 1$ s, a three-phase fault is introduced at bus 11. The fault is cleared after 0.1 s.

Observation:

- Electrical power P_e drops to zero as soon as the fault is introduced.
- After the fault is cleared, the rotor speed and gate position settles back to the pre-disturbance conditions, following their respective references.

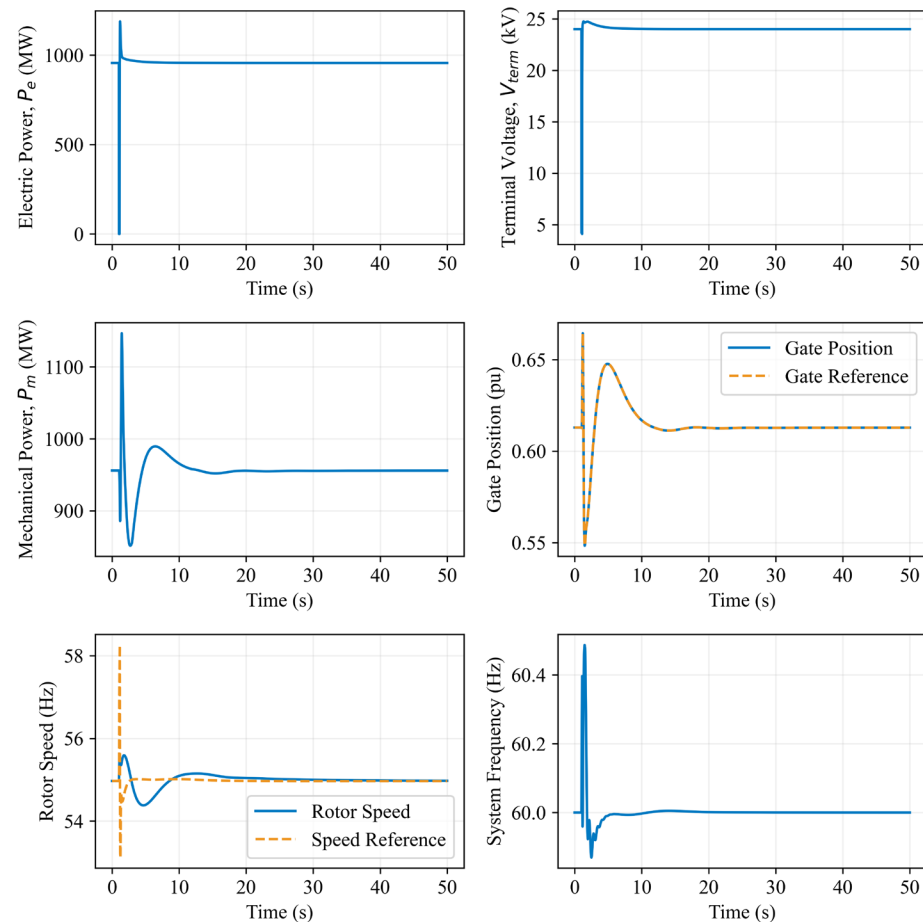

Figure 13: Time-domain simulation results of AS-PSH (Turbine Mode) from a three-phase fault.

Pump Mode: Load Trip

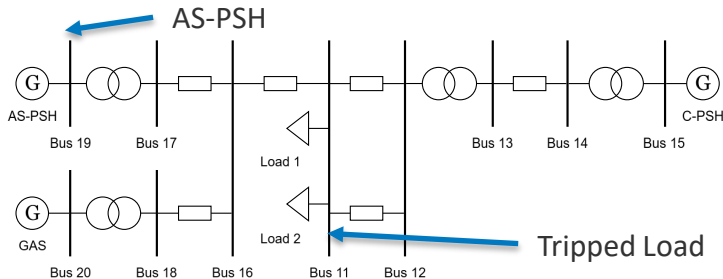

Figure 14: Load trip in 10-Bus Test System.

Test Condition:

- The AS-PSH is a 1276 MVA machine at bus 19.
- At $t = 1$ s, the 100 MW load at bus 11 is disconnected.

Observation:

- The unit adjusts its pumping power P_e to help counter the temporary generation surplus and restore system frequency.
- The gate reference and gate position both increase and settle at a new steady-state value to adjust the pumping power.

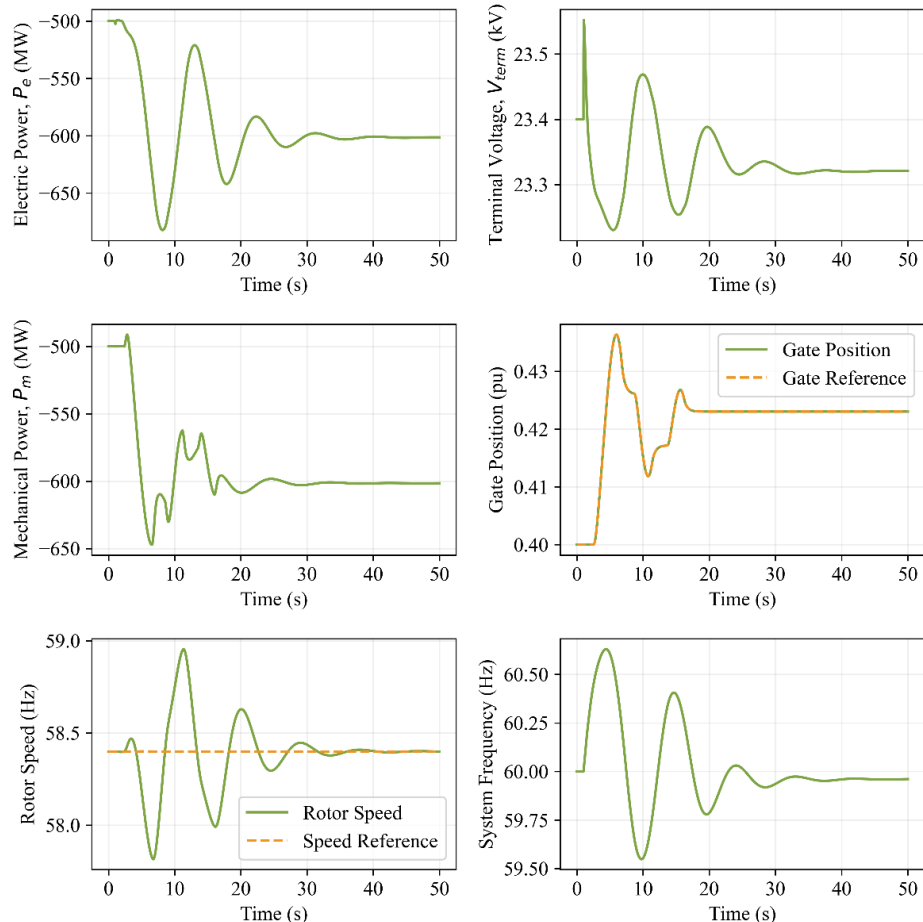

Figure 15: Time-domain simulation results of AS-PSH (Pump Mode) from a load trip event.

Pump Mode: Three Phase Fault

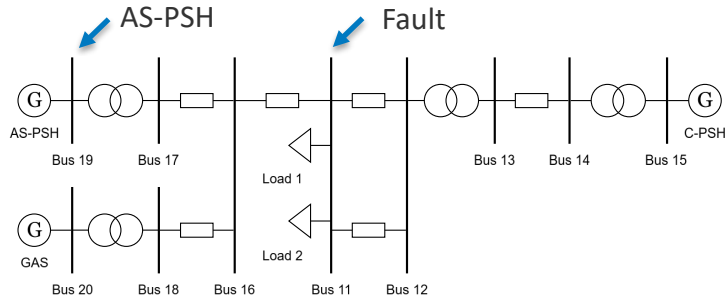

Figure 16: Three Phase Fault in 10-Bus Test System.

Test Condition:

- The AS-PSH is a 1276 MVA machine at bus 19.
- At $t = 1$ s, a three-phase fault is introduced at bus 11. The fault is cleared after 0.1 s.

Observation:

- The same fault is applied in pump mode and turbine mode, but the system reaches steady state faster in pump mode. This is because the pump was initially absorbing 500 MW, while in turbine mode the unit was generating 950 MW.
- The rotor speed reference is static because the optimizer does not change it in this range of P_m .

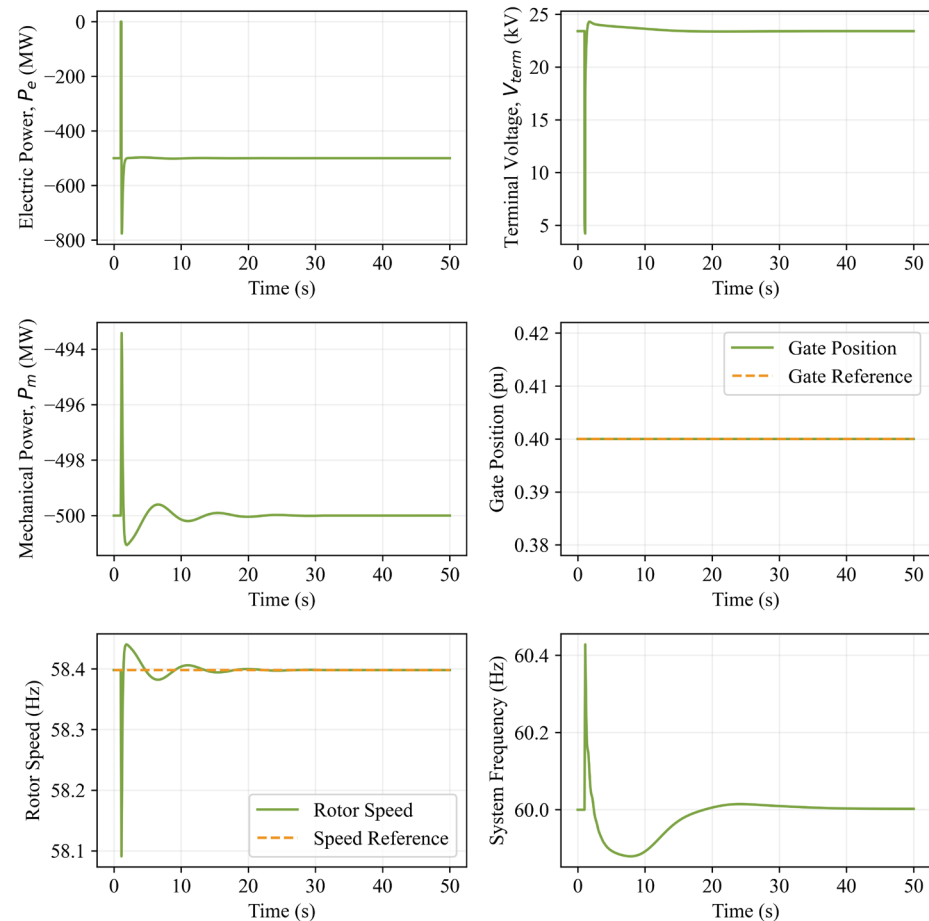
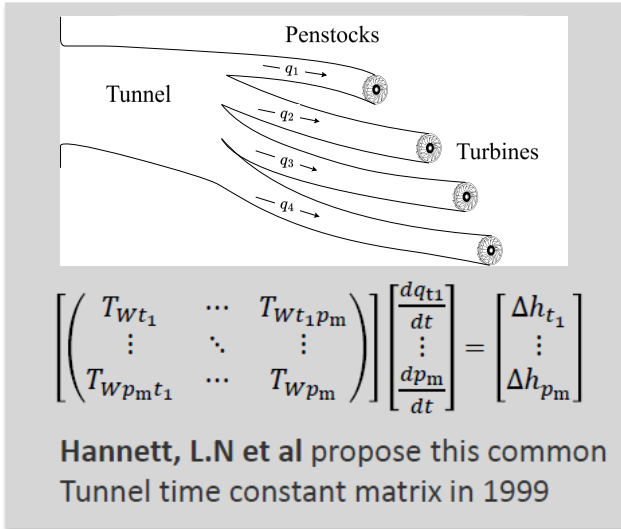

Figure 17: Time-domain simulation results of AS-PSH (Pump Mode) from a three-phase fault.

Shared Penstock



- **Water starting time constant T_w :** Represents the **hydraulic inertia** of the water column.
- **Diagonal terms T_w matrix:** Models the **common penstock + individual unit penstock** inertia.
- **Off-diagonal terms T_w matrix:** Represent the **hydraulic coupling** between units through the shared common penstock.

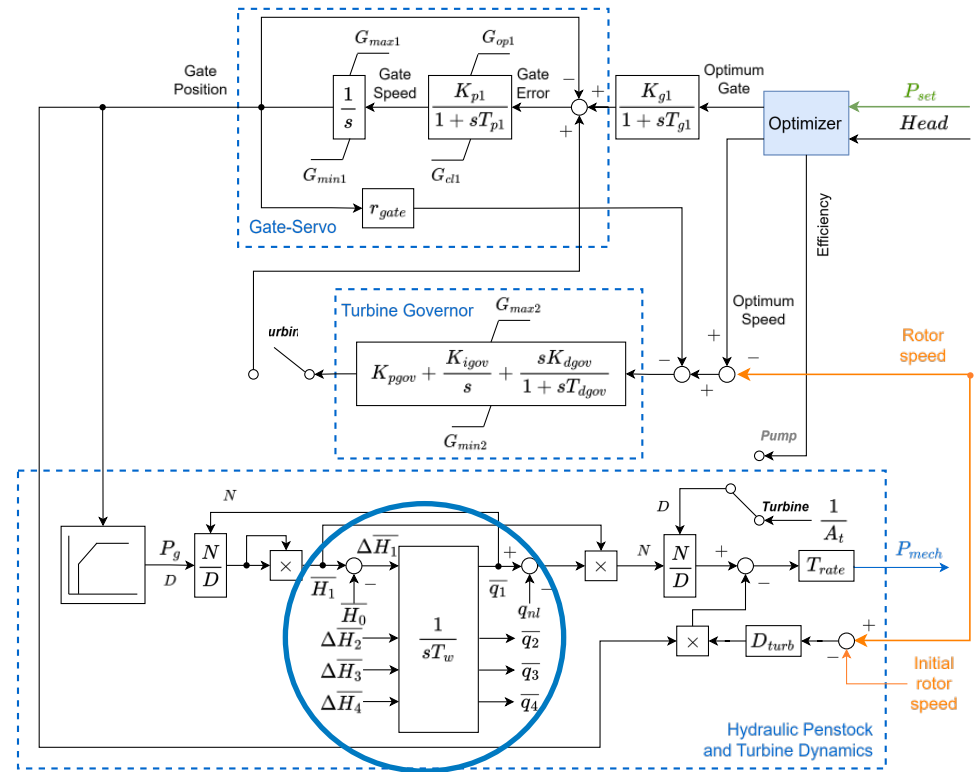

Figure 18: Turbine-Governor and Penstock Dynamics

Shared Penstock

- Symmetric case**

$$T_w = \begin{bmatrix} 0.84 & 0.52 & 0.52 & 0.52 \\ 0.52 & 0.84 & 0.52 & 0.52 \\ 0.52 & 0.52 & 0.84 & 0.52 \\ 0.52 & 0.52 & 0.52 & 0.84 \end{bmatrix}$$

Figure 19: Time-domain simulation results of four **symmetric** AS-PSH units (Turbine Mode) sharing a penstock during a load trip.

- Non-symmetric case**

$$T_w = \begin{bmatrix} 0.80 & 0.52 & 0.52 & 0.52 \\ 0.52 & 0.84 & 0.52 & 0.52 \\ 0.52 & 0.52 & 0.88 & 0.52 \\ 0.52 & 0.52 & 0.52 & 0.90 \end{bmatrix}$$

Figure 20: Time-domain simulation results of four **non-symmetric** AS-PSH units (Turbine Mode) sharing a penstock during a load trip.

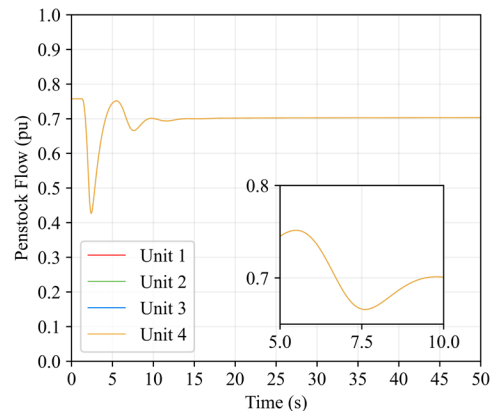
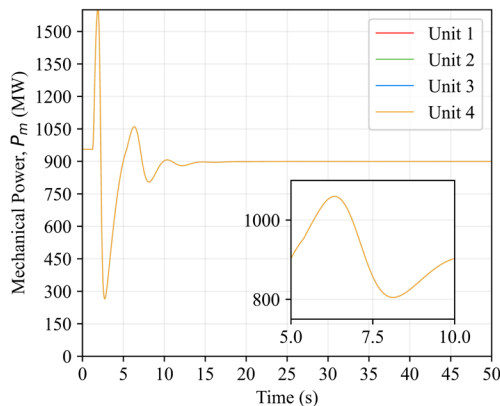
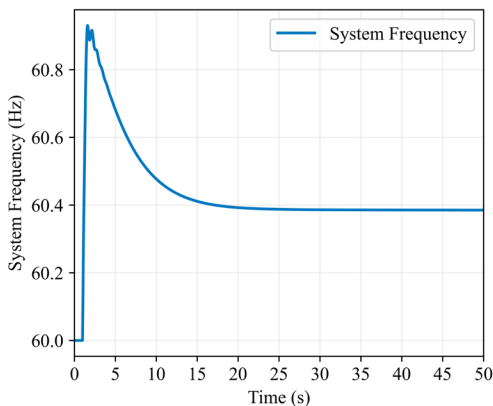
Summary

- Independent system operators, transmission system operators, and developers require AS-PSH model to evaluate the impacts of newly advanced PSH projects on interconnection study.
- This specification presents a generic User-Defined Model for AS-PSH (Type 3).
- The model represents both generating and pumping operation with variable-speed control.
- Full dynamic Model = AS-PSH UDM + WT3G2 Model

Next steps

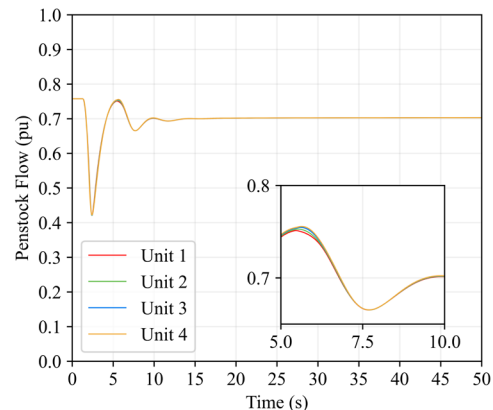
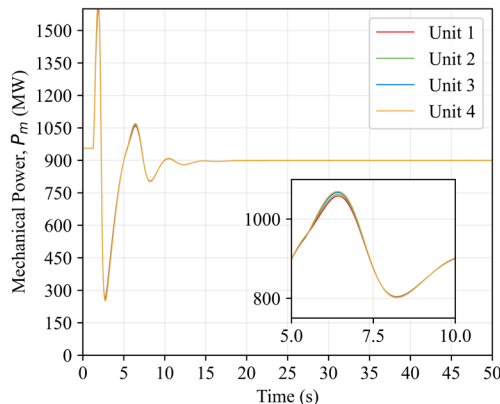
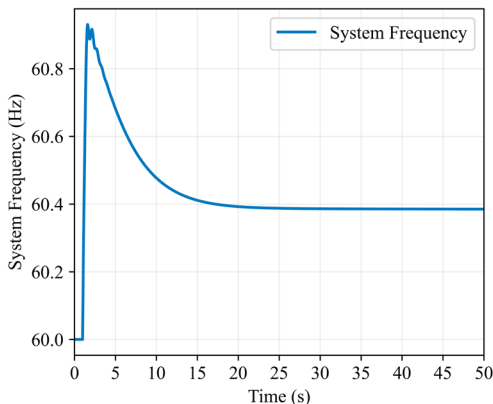
- Present the progress at the WECC Modeling and Validation Subcommittee (MVS) meeting in May 2026 and gather industry feedback.
- Incorporate feedback from GE and Obermeyer Hydro into the final specification and perform parameter calibration if needed.
- Share the updated specification with the WECC MVS in July 2026.

Acknowledgments

- This specification development builds upon the Type 3 Adjustable-Speed Pumped Storage Hydropower (AS-PSH) modeling work supported by the **U.S. Department of Energy CMEI office (Water Power Technologies Office (WPTO))**, under the **“Mitigation of Modeling Gaps”** project.
- The modeling approach was mainly developed with reference to hydro modeling reports from Argonne National Laboratory and IEEE Task Force reports titled “Advanced Pumped Storage Hydropower Modeling” led by Ed Muljadi.
- We sincerely appreciate **Phil Hart** and **Song Wang**’s support in coordinating reviews with experts from **GE**. Also thank **Obermeyer Hydro** for their valuable engagement and feedback during the specification review process.
- We also gratefully acknowledge the valuable review comments provided during the first review round by **Zerui Dong** from OPAL-RT, **Jinko Kim** from Pacific Northwest National Laboratory (PNNL), and **Ed Muljadi** from Auburn University.

References

- Global Energy Monitor. 2026. “Summary Tables.” *Global Hydropower Tracker*. Accessed May 5, 2026. <https://globalenergymonitor.org/projects/global-hydropower-tracker/summary-tables/>
- Koritarov, V., Q. Ploussard, J. Kwon, and P. Balducci. 2022. *A Review of Technology Innovations for Pumped Storage Hydropower*. ANL-22/08. DOI: 10.2172/1867238.
- Koritarov, V., et al. 2013. *Modeling Adjustable Speed Pumped Storage Hydro Units Employing Doubly-Fed Induction Machines*. ANL/DIS-13/06. DOI: 10.2172/1098021.
- Koritarov, V., J. Feltes, Y. Kazachkov, B. Gong, P. Donalek, and V. Gevorgian. 2013. *Testing Dynamic Simulation Models for Different Types of Advanced Pumped Storage Hydro Units*. ANL/DIS-13/08. DOI: 10.2172/1098023.
- IEEE Power & Energy Society Power System Dynamic and Performance Committee Adjustable-Speed Pumped Storage Hydro Task Force. 2025. *Advanced Pumped Storage Hydropower Modeling*. Technical Report PES-TR 134. June 2025.
- CORDIS. 2016. “Variable Speed Pumped Storage Hydro Plants Offer a New Era of Smarter Energy Management.” Accessed May 5, 2026. <https://cordis.europa.eu/article/id/119319-variable-speed-pumped-storage-hydro-plants-offer-a-new-era-of-smarter-energy-management>
- National Hydropower Association. 2021. “New Variable-Speed Pumped Storage Projects Will Provide Huge Value to U.S. Transmission Grid.” Accessed May 5, 2026. <https://www.hydro.org/powerhouse/article/new-variable-speed-pumped-storage-projects-will-provide-huge-value-to-u-s-transmission-grid/>
- Shao, M., X. Guo, C. Bisceglia, G. de Mijolla, S. Rao, S. Pajic, E. Ibanez, M. Bringolf, and D. Havard. 2021. *Value and Role of Pumped Storage Hydro under High Variable Renewables*. DOE-GE-0008782. DOI: 10.2172/1824300.

References

- Muljadi, E., R. Nelms, E. Chartan, R. Robichaud, L. George, and H. Obermeyer. 2021. *Electrical Systems of Pumped Storage Hydropower Plants: Electrical Generation, Machines, Power Electronics, and Power Systems*. Golden, CO: National Renewable Energy Laboratory. NREL/TP-5000-74721. DOI: 10.2172/1804447.
- Muljadi, E., M. Singh, V. Gevorgian, M. Mohanpurkar, R. Hovsopian, and V. Koritarov. 2015. “Dynamic Modeling of Adjustable-Speed Pumped Storage Hydropower Plant.” Presented at *2015 IEEE Power & Energy Society General Meeting*, Denver, CO, July 2015. DOI: 10.1109/PESGM.2015.7286214.
- XFLEX HYDRO. n.d. “Frades 2.” Accessed May 5, 2026, <https://www.xflexhydro.com/test-sites/frades-2>
- ABB, “Large-Scale Pumped Storage in Switzerland.” Accessed May 5, 2026, <https://new.abb.com/power-generation/references/large-scale-pumped-storage-in-switzerland>
- Vasudevan, K. R., V. K. Ramachandaramurthy, G. Venugopal, J. B. Ekanayake, and S. K. Tiong. 2021. “Variable Speed Pumped Hydro Storage: A Review of Converters, Controls and Energy Management Strategies.” *Renewable and Sustainable Energy Reviews* 135: 110156.
- Guo, L., C. Xu, F. Zhang, F. Deng, X. Ai, and F. Xue. 2025. “Variable Speed Pumped Storage Units in China: Current Status and Development.” *Energy Reports* 13: 2815–2828.
- Bidgoli, M. A., W. Yang, and A. Ahmadian. 2020. “DFIM versus Synchronous Machine for Variable Speed Pumped Storage Hydropower Plants: A Comparative Evaluation of Technical Performance.” *Renewable Energy* 159: 72–86.

Thank you & Questions

Contact:

Jin Tan

Jin.tan@nlr.gov

www.nlr.gov

This work was authored by the National Laboratory of the Rockies for the U.S. Department of Energy (DOE), operated under Contract No. DE-AC36-08GO28308. Funding provided by U.S. Department of Energy Office of Critical Minerals and Energy Innovation Hydropower and Hydrokinetic Office. The views expressed in the article do not necessarily represent the views of the DOE or the U.S. Government. The U.S. Government retains and the publisher, by accepting the article for publication, acknowledges that the U.S. Government retains a nonexclusive, paid-up, irrevocable, worldwide license to publish or reproduce the published form of this work, or allow others to do so, for U.S. Government purposes.

NATIONAL
LABORATORY
OF THE ROCKIES