

# PERC1 model

EPRI



L. Sundaresh

P. Mitra

# Key Data Center Challenges Impacting BPS Stability

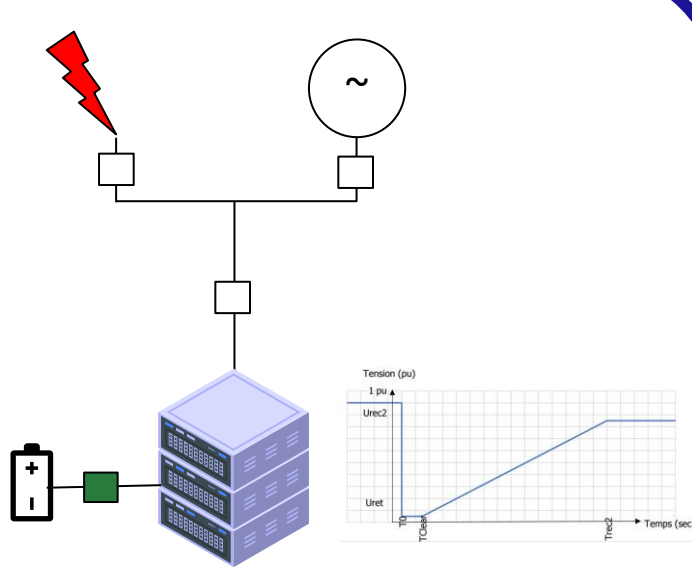

The diagram shows a power source (red lightning bolt) and a generator (circle with a tilde symbol) connected to a bus. A circuit breaker is shown in the open position, indicating a disturbance. Below the bus, a battery and a server rack are connected. A graph plots Tension (pu) on the y-axis against Temps (sec) on the x-axis. The graph shows a step change in Urec2 and a ramp in Urec1, with a vertical line marking Trec1.

**Unanticipated Data center load disconnection after a disturbance in the grid**

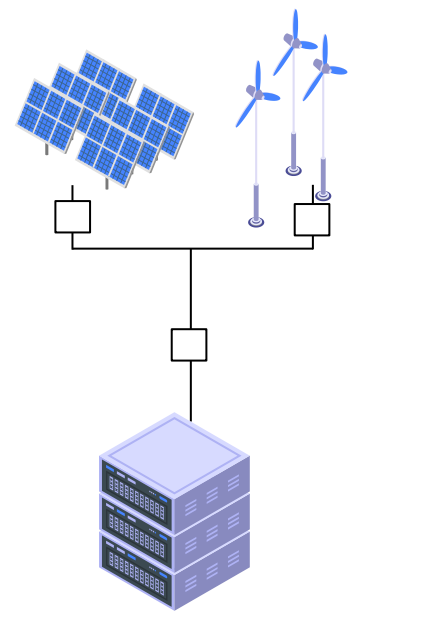

The diagram shows a power source (solar panels and wind turbines) connected to a bus. A circuit breaker is shown in the closed position. Below the bus, a server rack is connected.

**Data center control interactions with IBRs and close by generation**

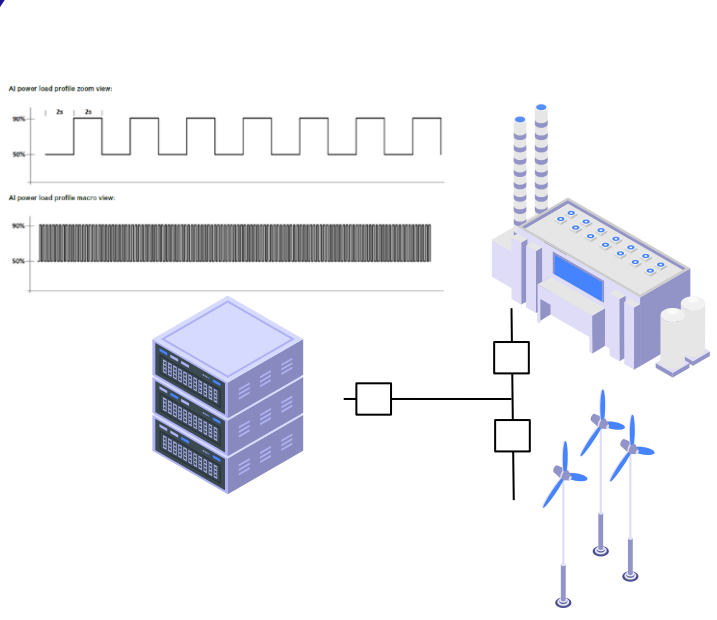

The diagram shows a server rack connected to a bus, which is connected to a power source (wind turbines). A graph plots AI power load profile zoom view on the y-axis against Temps (sec) on the x-axis. The graph shows a step change in AI power load. A second graph plots AI power load profile macro view on the y-axis against Temps (sec) on the x-axis. The graph shows a high-frequency, high-amplitude signal. A factory icon is also present.

**AI training and its impact on BPS stability**

# Key components of data center

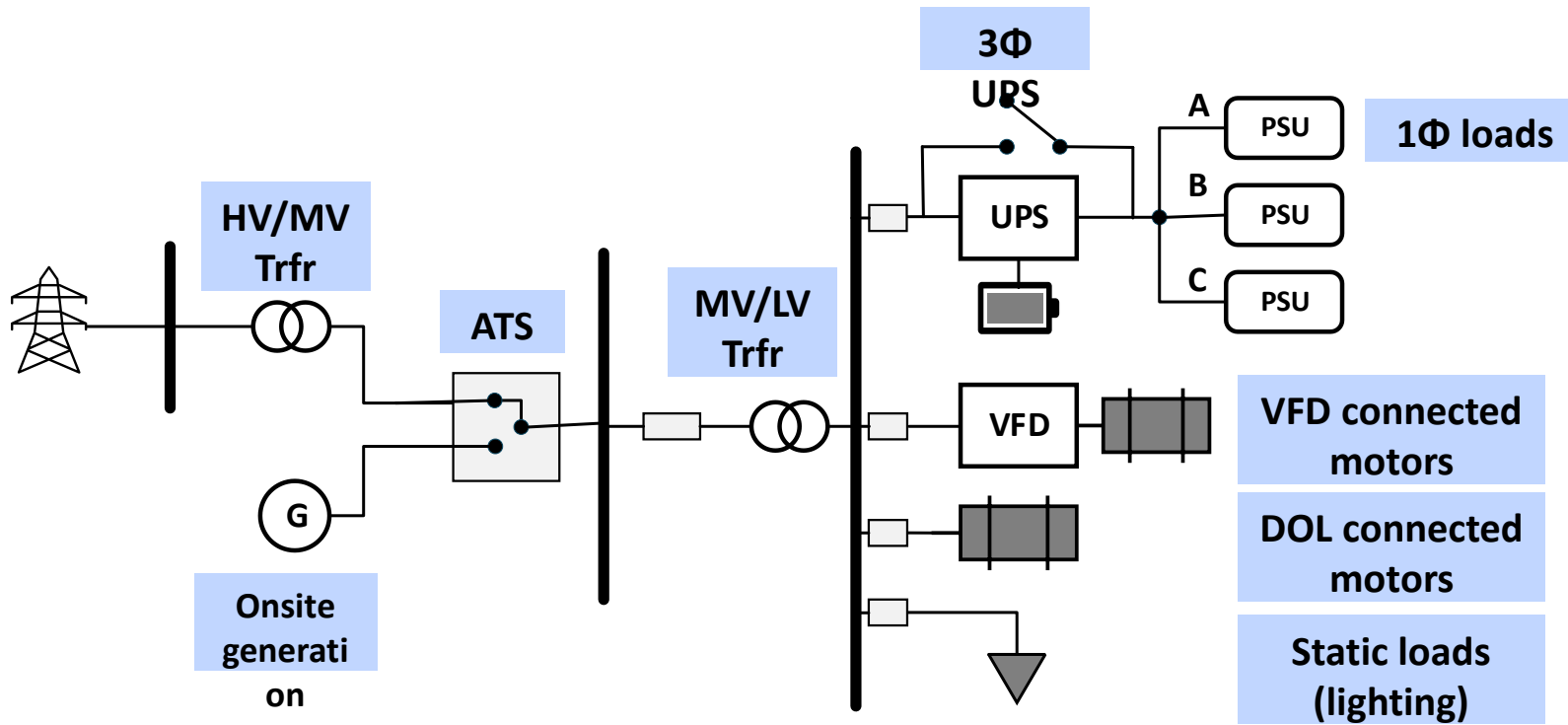

*About 90% of the total load is electronically driven (Switched Mode Power Supplies and Electronic Drives)*

*The main electrical equipment that interfaces with the grid are:*

- *Uninterruptible power supply*
- *Single phase power supply units (\*)*
- *Variable speed drives/direct connected motors*
- *Lighting (LED)*
- *Battery Energy Storage/Power Conditioning Equipment (\*)*

# Behavior during Transient and Steady State

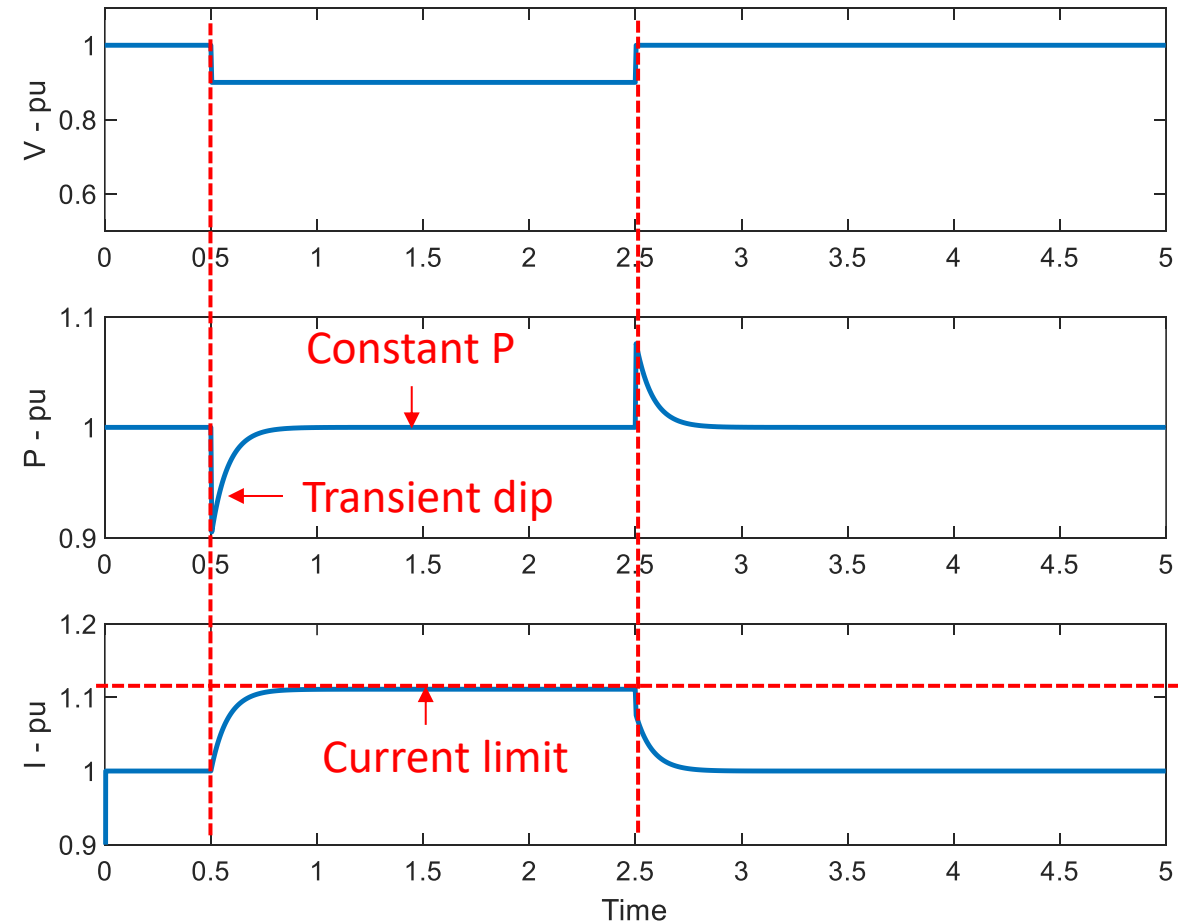
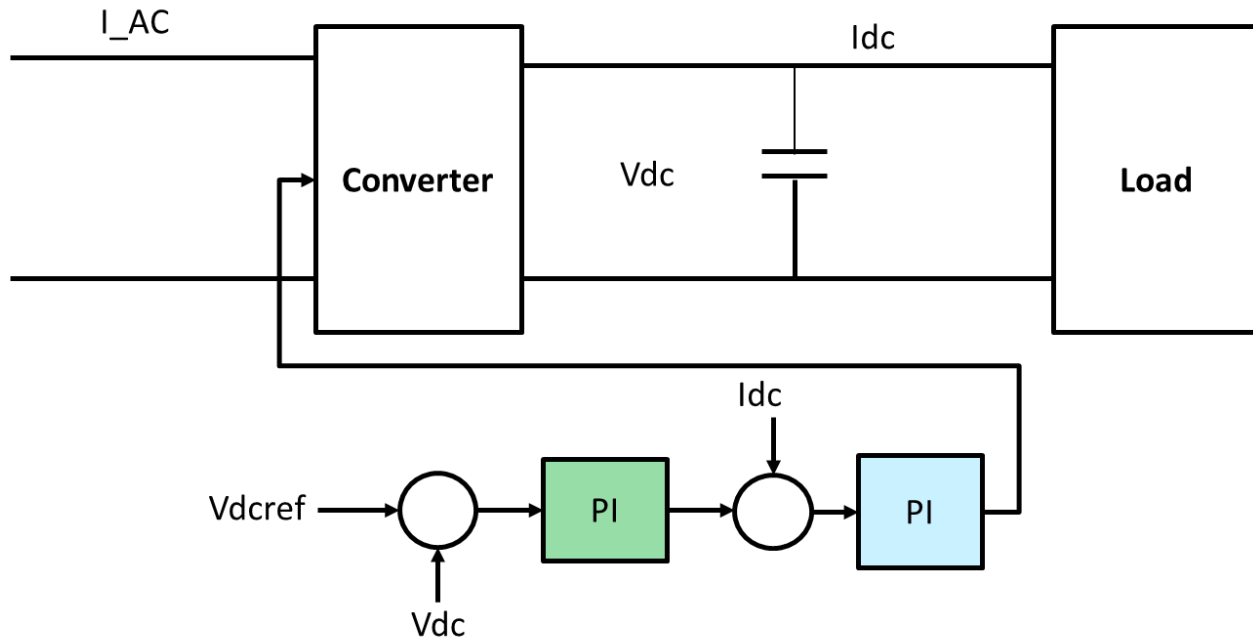

This behavior is only applicable for V dip up to 0.7 pu as the load moves to the battery below that threshold

# Load Characteristic PERC1

## Load Characteristic PERC1 Power Electronic Load Model With Reconnecting and Ceasing

States
1 - Pctrl
2 - Qctrl
3 - dP
4 - dQ
5 - wfilt
6 - Vfilt
7 - Ip
8 - Iq

Others
1 - Pmw
2 - Qmvar
3 - Ipv
4 - Iqv
5 - FracOn

$$MBase = \left( \frac{MW_{init}}{Lfm} \right)$$

$V_{init}$  = Voltage per unit in initial condition

$MW_{init}$  = MW in initial condition

$Mvar_{init} = QP_{ratio} * MW_{init}$

If used inside a modular load model, then  $I_{qvextra} = 0$  and mismatch of Mvar is handled during the initialization of the CompLoad components.

If used as a stand-alone model, then  $I_{qvextra} = \frac{QMvar - Mvar_{init}}{MBase * V_{init}}$

IF ( $V_{init} < V_{cease}$ )  
OR ( $V_{init} < MinVoltIload$ )  
OR ( $MW_{init} = 0$ )

THEN this model will be ignored, and a constant impedance used instead

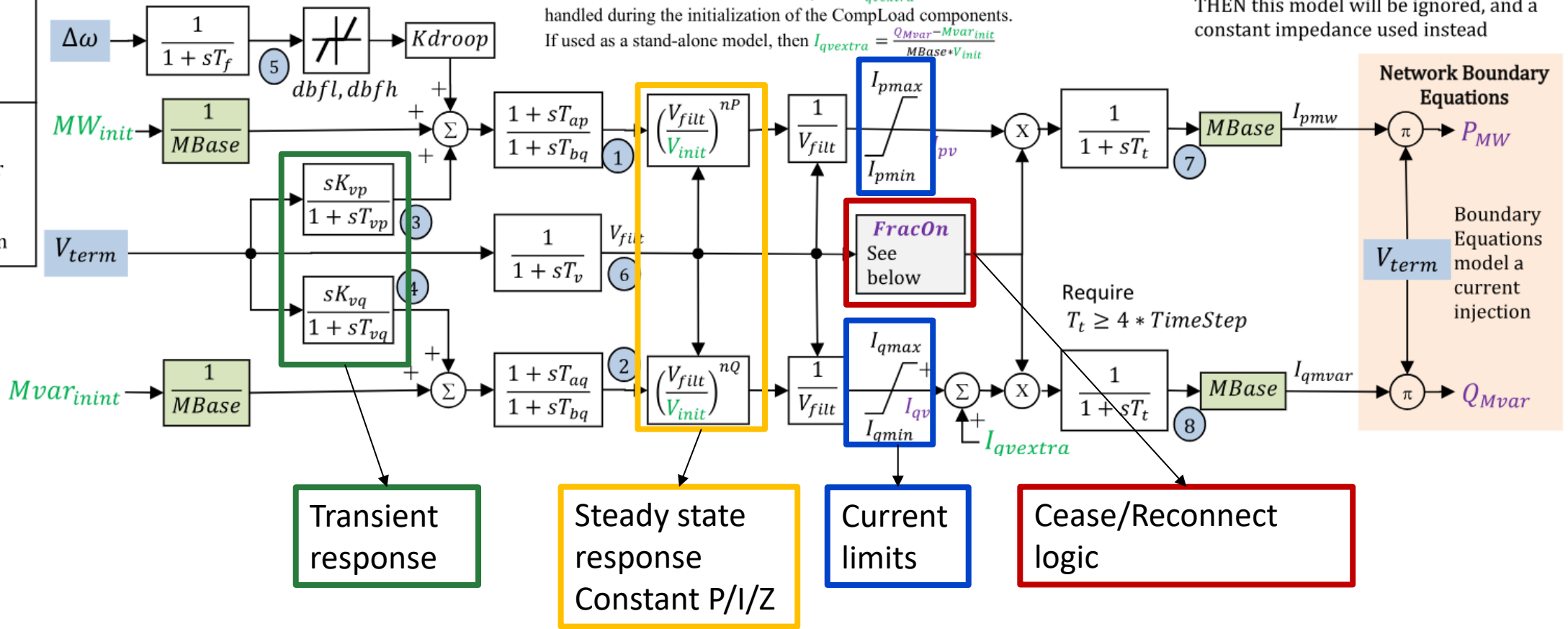

# Washout filter response

- Model can be used to capture various first order transient response

Varying K (T fixed)

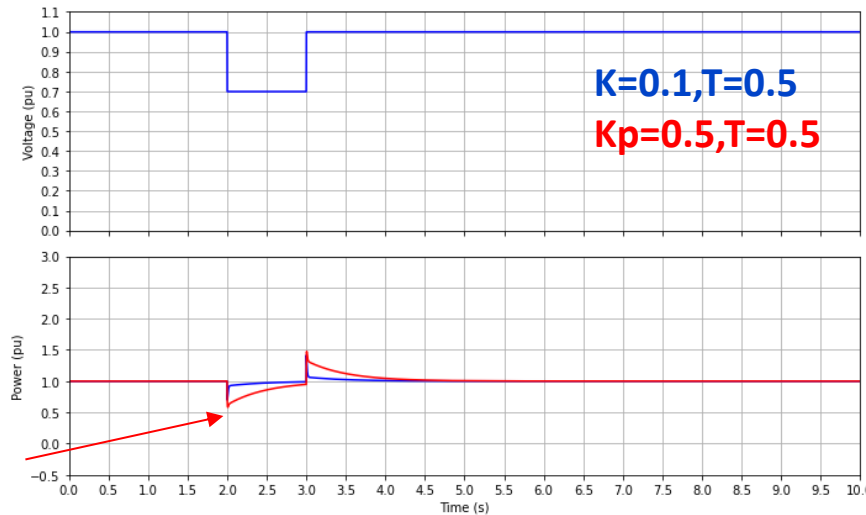

Increased spike,  
fixed decay

Varying T (K fixed)

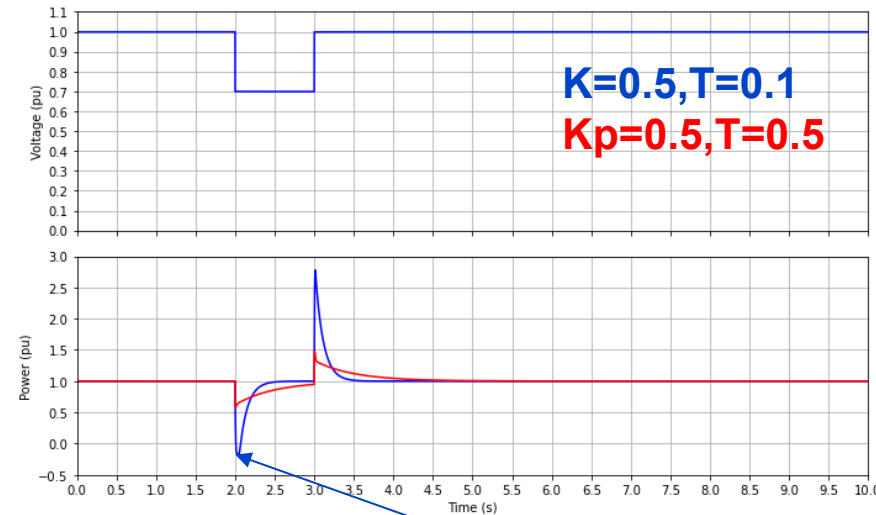

Varying K & T (K/T fixed)

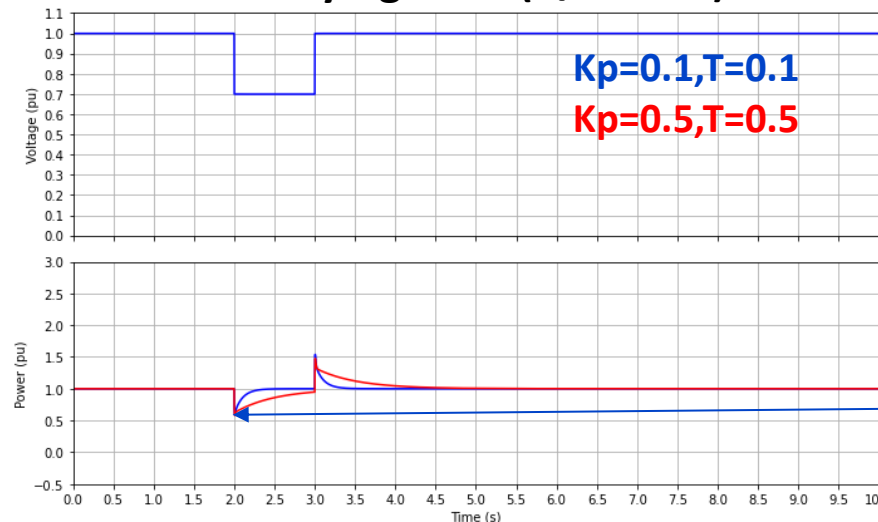

Increased spike,  
Faster decay

Fixed spike,  
different decay

$$G(s) = \frac{Ks}{1+Ts}; \quad y(t) = A(K/T)e^{-(t-1)/T}u(t-1)$$

# Model can be used to capture current limiting

Model can be used to capture current limiting

Set IPMAX=1.1

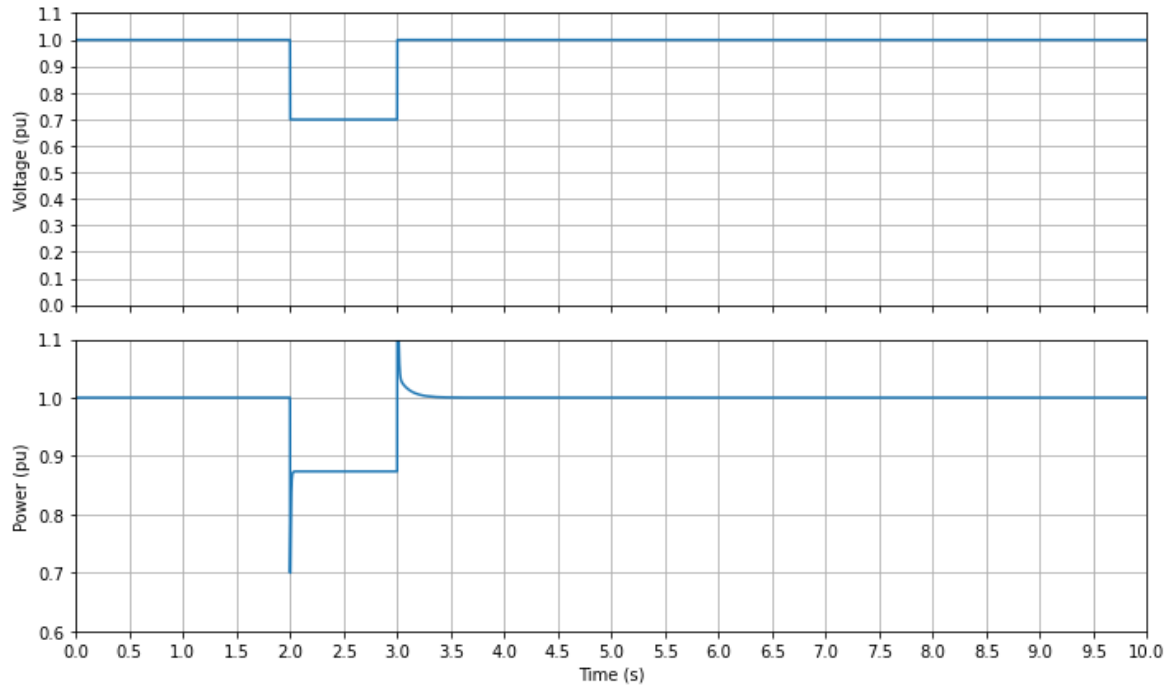

Model can be used to capture constant current steady state response

Set IPMAX=999

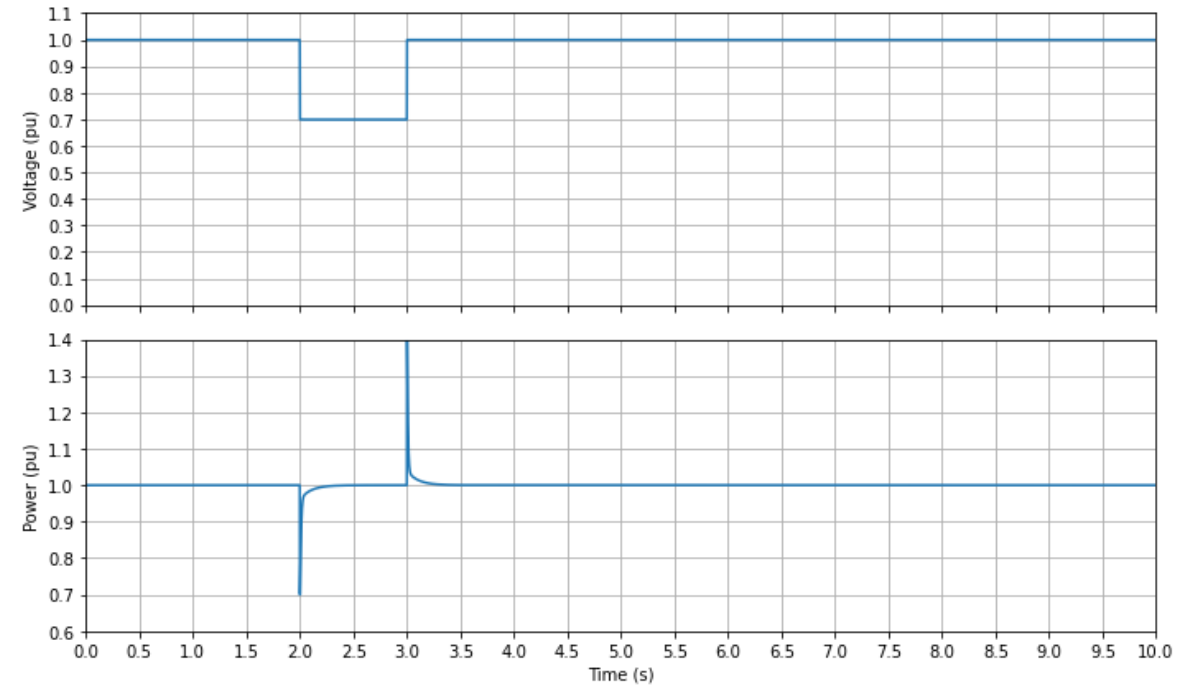

# Capability of the phasor model

Model can be used to capture constant power steady state response

Set NPA=0

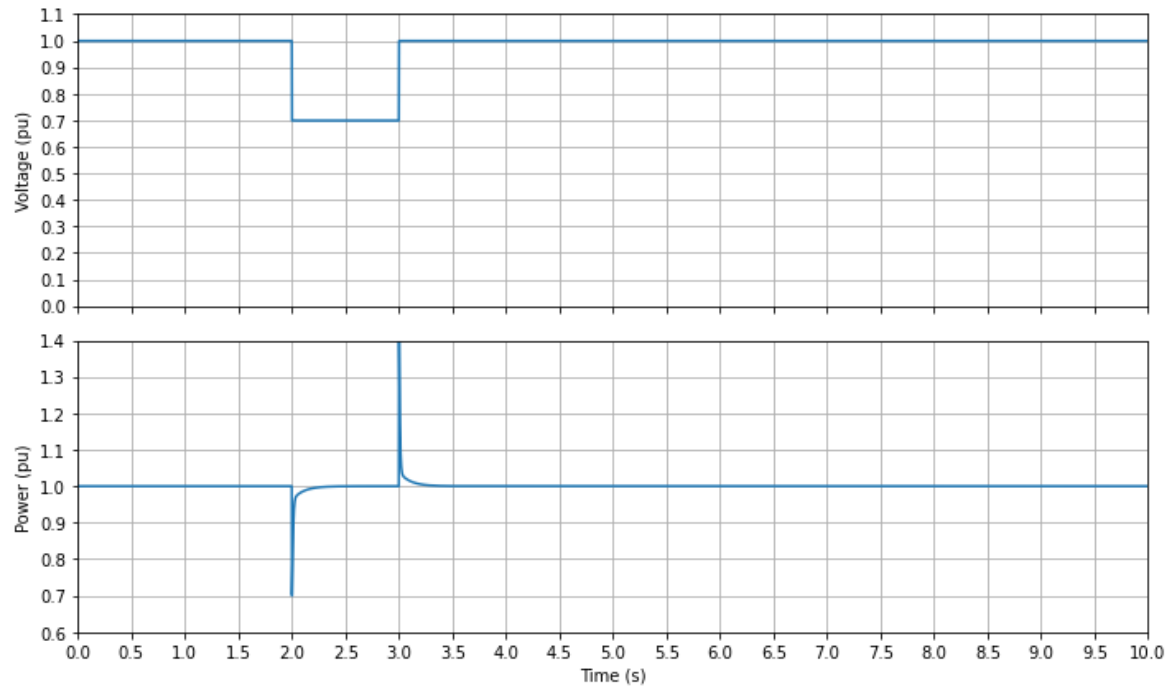

Model can be used to capture constant current steady state response

Set NPA=1

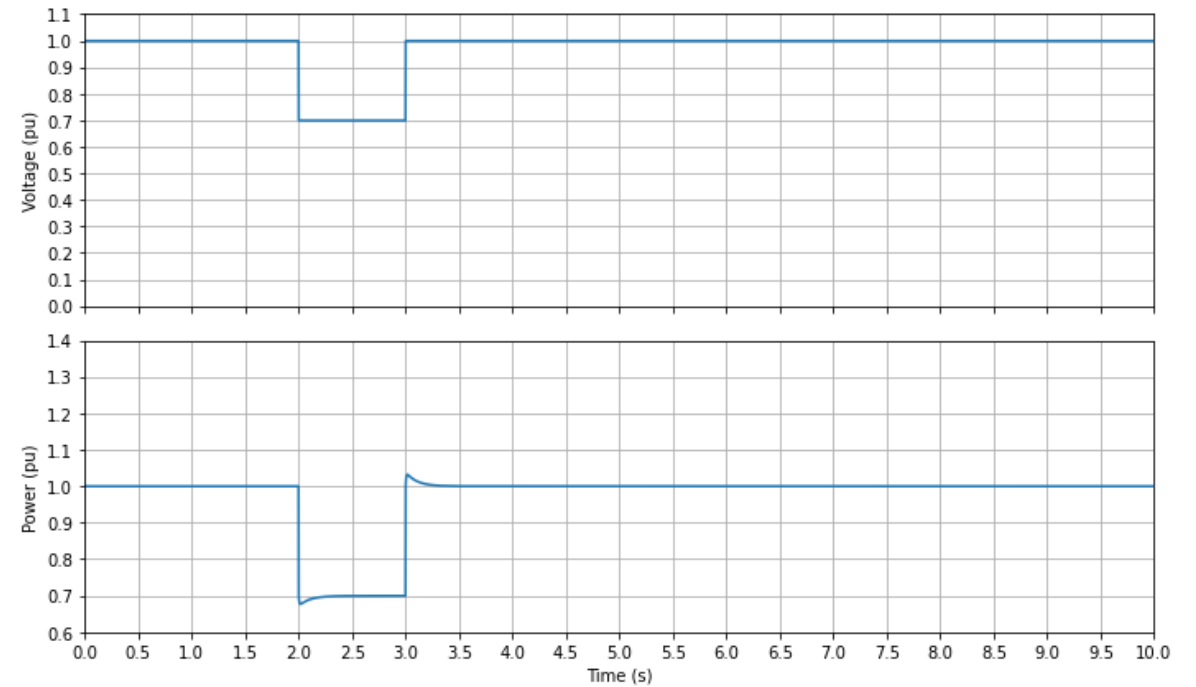

# Key control loops and parameters (EMT)

DC capacitor size

Bandwidth of controllers

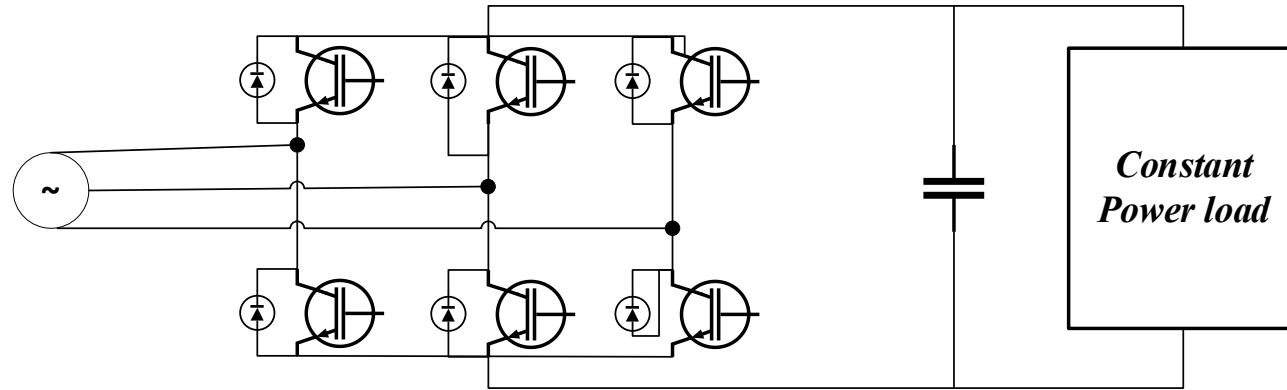

Cap size	500 mF	80mF
Outer loop DC	23.0 Hz	100Hz
power factor	7 Hz	17.5 Hz
Inner loop current	~256 Hz	~250 Hz

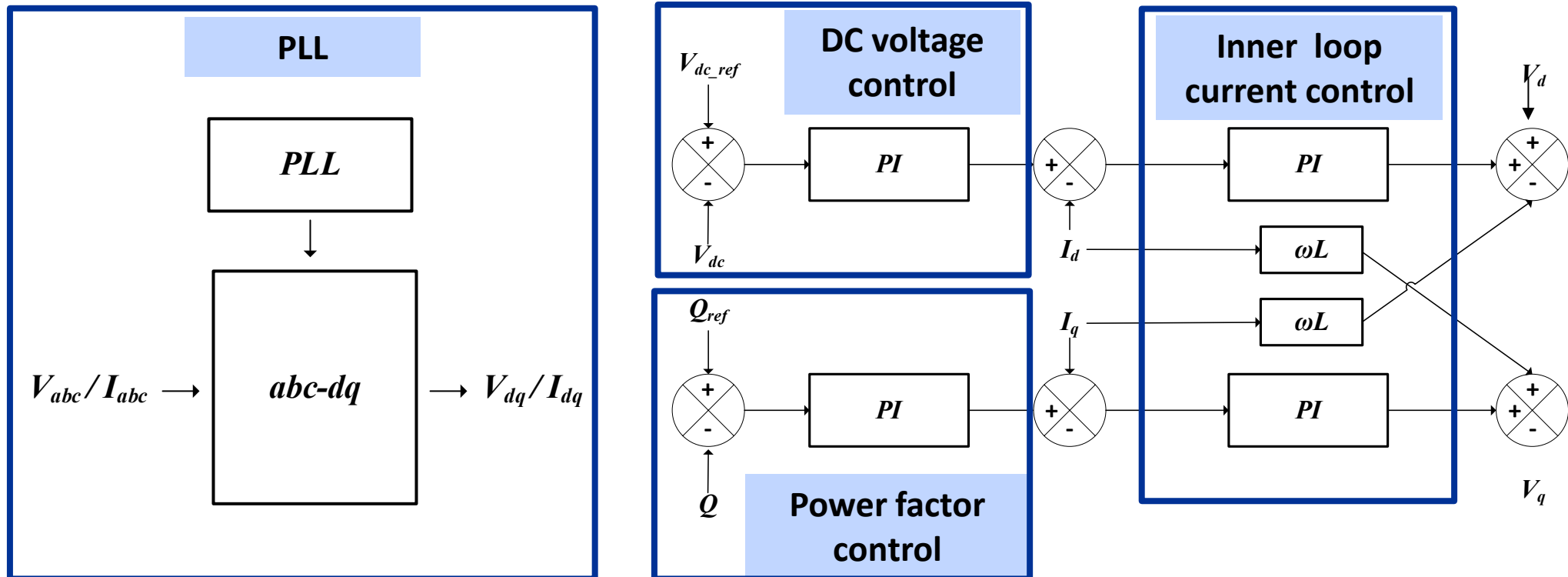

# Comparison of the phasor/EMT model

Deep sag

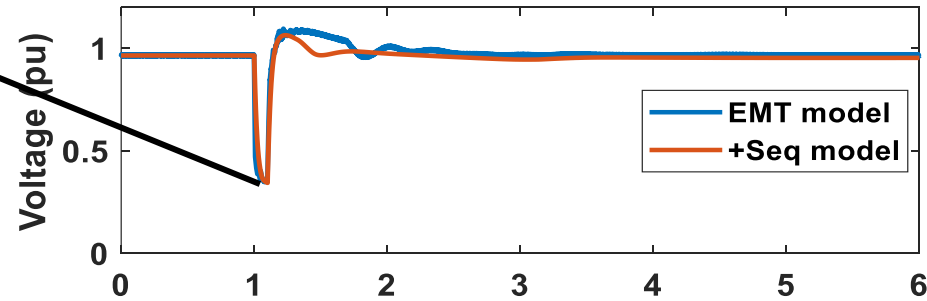

$I_{max}$  is set at 1.1 pu, rectifier reaches the limit triggering the power transfer to battery

The power from grid reduces to zero

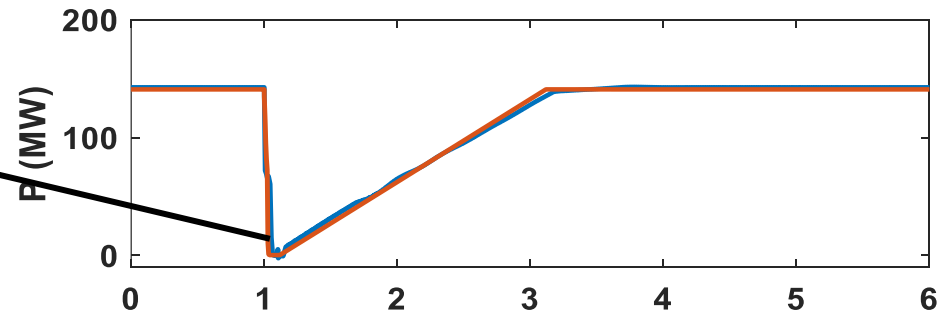

Once the voltage recovers, the active/reactive power is ramped to reach pre-fault levels

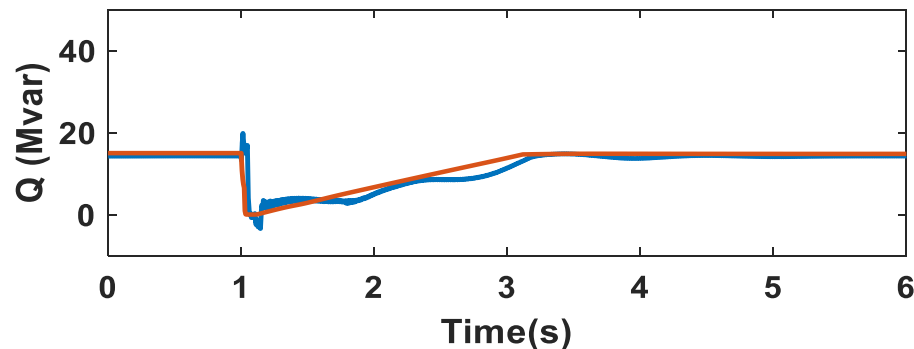

**EMT and Phasor model have good agreement**

# Spectrum of Modeling: From Requirements to Future Facilities

## Development of Ride through Requirements

- Policy / expectation-driven modeling
  - Defines minimum expected behavior
  - Used for:
    - Interconnection requirements
    - Planning studies
  - Conservative and uniform assumptions
- what the grid expects, not what every facility actually does

## Modeling of existing facilities for planning/operations

- Reality-driven modeling
- Represents actual facility behavior
- Based on:
  - NERC questionnaires
  - Utility and site data
- Validated using:
  - Measurements

What really happens on my system today

## Modeling of Planned and Future Facilities

- Assumption-driven modeling
- Based on assumptions and benchmarking
- High uncertainty in controls and operation
- Sensitivity studies are essential
- Often informed by emerging standards

# Modeling using component level

Component level modeling

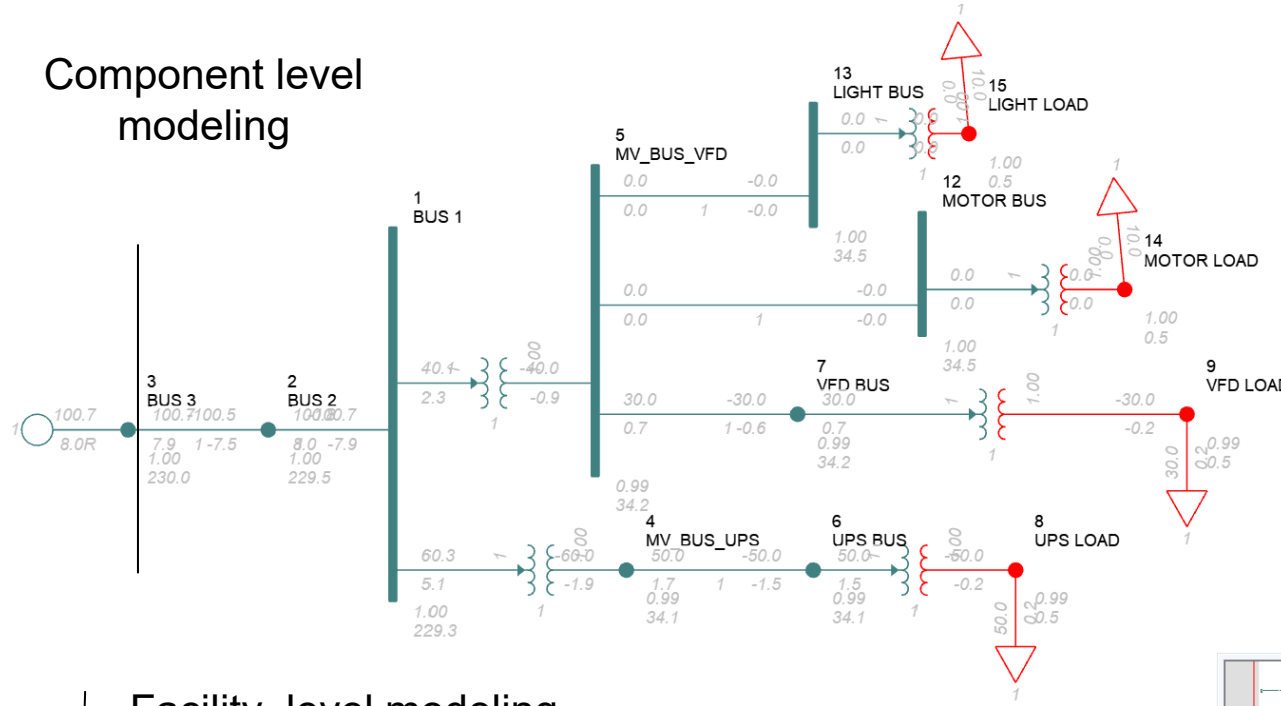

Facility level modeling

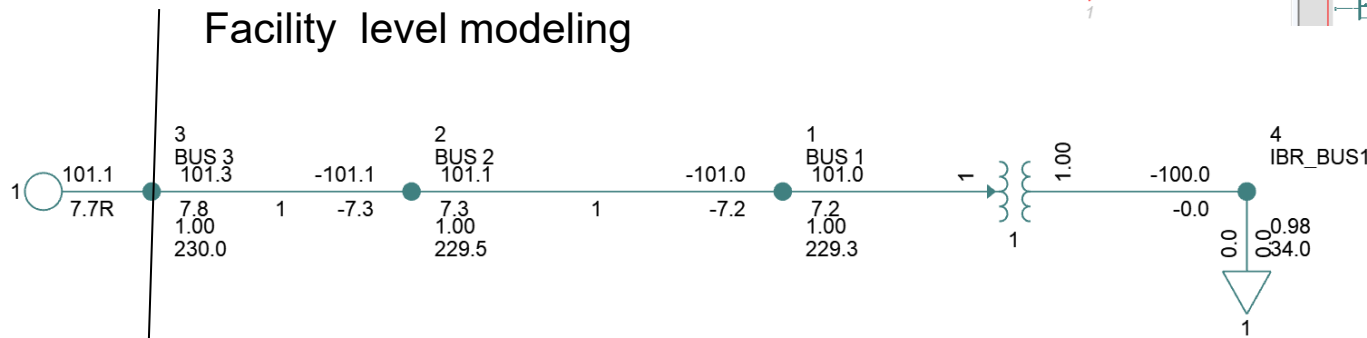

Load	MW	Dynamic model
Light load	10	Constant P
Motor Load	10	CIM5BL
VFD Load	30	PERC1
UPS Load	50	PERC1

Load	MW	Dynamic model
Complete load	100	PERC1

# Comparison of the simulation

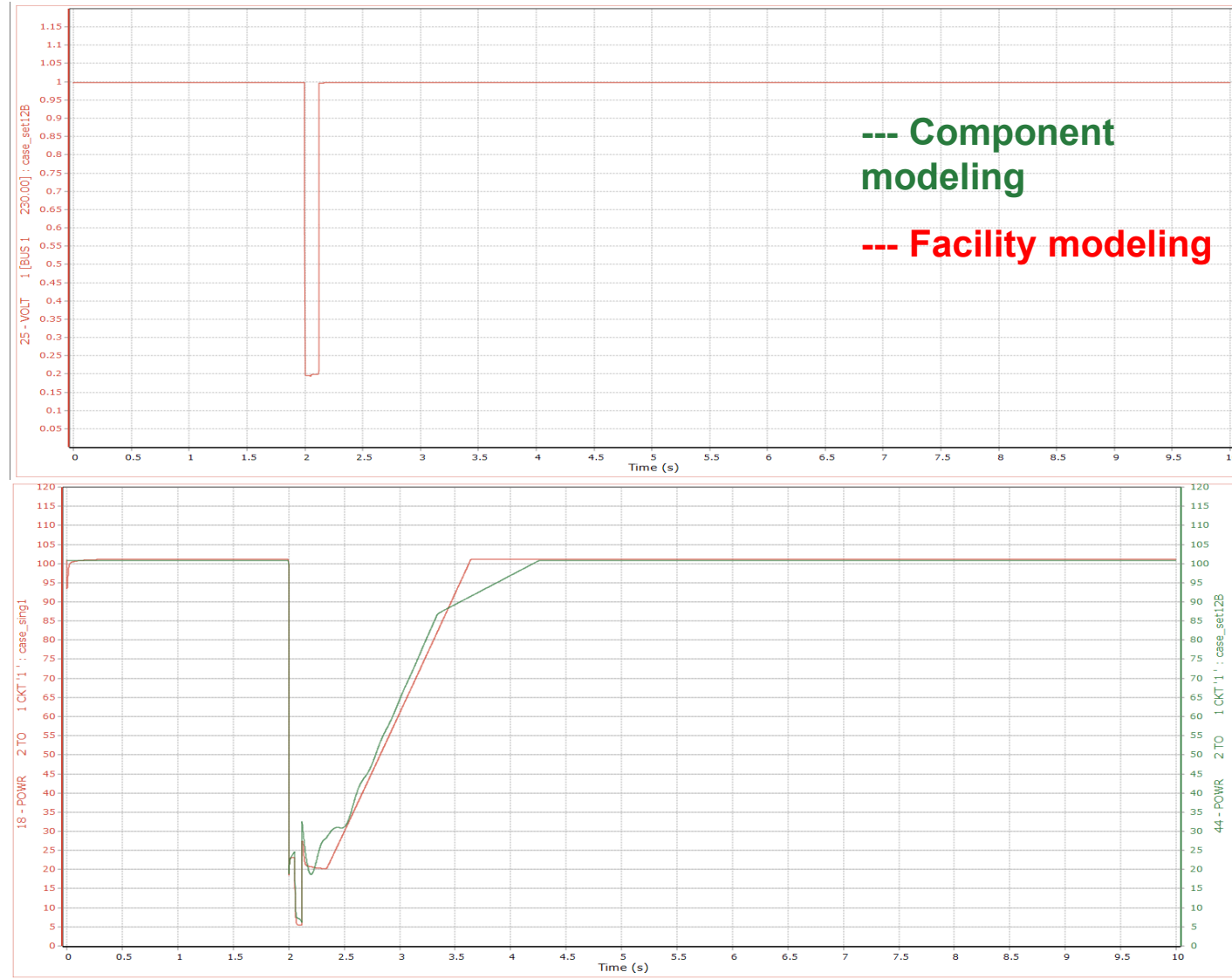

# EPRI guidance on data center modeling

- **Existing phasor models (PERC1) are recommended for transmission planning studies.**
- **Under low short-circuit conditions, detailed EMT (Electromagnetic Transients) studies are recommended to identify and mitigate potential risks that may not be captured by phasor-based simulations.**
- **Obtain detailed EMT models directly from vendors, to capture equipment specific dynamics that might be of interest.**

# Future work

- **Refine the current phasor model** using insights from sensitivity analysis performed with detailed EMT models.
- **Develop models for new DC power supply topologies** based on the latest vendor specifications.
- **Incorporate various distribution architectures** proposed for upcoming data centers into the modeling framework.



**TOGETHER...SHAPING THE FUTURE OF ENERGY®**