

Document Title	WECC Guide for Representation of Photovoltaic Systems in Large-Scale Load Flow Simulations
File Name	WECCPVPlantPowerFlowModelingGuide.pdf
Category	<input type="checkbox"/> Regional reliability standard <input type="checkbox"/> Regional criteria <input type="checkbox"/> Policy <input checked="" type="checkbox"/> Guideline <input type="checkbox"/> Report or other <input type="checkbox"/> Charter
Document date	August 2010
Adopted/approved by	M&VWG/TSS
Date adopted/approved	January 2011
Custodian (entity responsible for maintenance and upkeep)	M&VWG
Stored/filed	Physical location: Web URL:
Previous name/number	WECC PV Plant Power Flow Modeling Guidelines - August 2010.doc
Status	<input checked="" type="checkbox"/> in effect <input type="checkbox"/> usable, minor formatting/editing required <input type="checkbox"/> modification needed <input type="checkbox"/> superceded by _____ <input type="checkbox"/> other _____ <input type="checkbox"/> obsolete/archived)

WECC Guideline:
WECC Guide for Representation of Photovoltaic Systems in Large-Scale Load Flow Simulations
Date: 11/2010

Introduction

This guideline provides guidance for aggregating photovoltaic power plants for power flow modeling.

Approved By:

Approving Committee, Entity or Person	Date
WECC Modeling and Validation Work Group	November 19, 2010
WECC Technical Studies Subcommittee	January 2011



**Western Electricity Coordinating Council
Modeling and Validation Work Group**

**WECC Guide for Representation of Photovoltaic Systems
In Large-Scale Load Flow Simulations**

**Prepared by
WECC Renewable Energy Modeling Task Force**

August 2010

1. Introduction

A large amount of PV generation is projected to be installed in the Western Interconnection in the form of distribution-connected commercial or residential installations, and transmission-connected large-scale plants. There is wide consensus that representation of PV systems in large-scale simulations needs to be improved to capture the potential effect on local areas as well as the overall system. The Modeling and Validation Work Group (MVWG) of the Western Electricity Coordinating Council (WECC) recently expanded the scope of its Renewable Energy Modeling Task Force (REMTF) to address modeling of PV systems¹.

This document contains technical guidelines issued by REMTF for representation of distribution-connected and transmission-connected photovoltaic plants for bulk-system load flow simulations in WECC. Although the intention is to address NERC MOD standards for regional planning, portions of these guidelines may also be considered for interconnection studies. The REMTF is currently working on generic positive-sequence dynamic models for PV plants, including transmission-connected and distribution-connected. A separate REMTF document covering dynamic representation will be issued.

2. Brief Background

2.1 General Characteristics

In a PV system, the PV array converts solar radiation directly into direct current (DC) electricity. At a given solar irradiance and cell temperature, the current and power output of the array is a function of terminal voltage, as shown in Figure 1. The voltage Vs. current characteristic (or IV curve) is nonlinear. There is a voltage level at which maximum power is extracted for a given irradiance level. The available current and power varies in proportion to the effective irradiance incident on the plane of the array. Temperature effects are secondary compared to irradiance, with lower temperature yielding higher performance. Irradiance level, ambient temperature, wind speed affect cell temperature. To maximize energy capture, some PV arrays are mounted on sun-tracking structures.

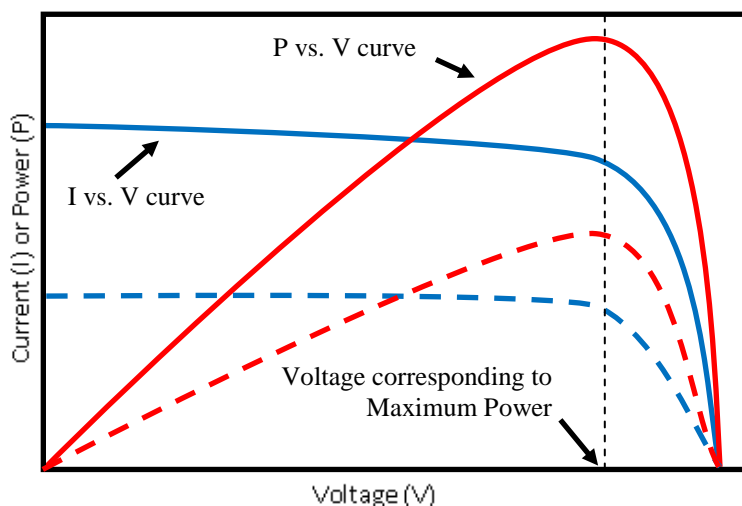

Figure 1 – PV array DC terminal characteristics, dotted lines representing a lower irradiance level.

¹ The REMTF, formerly known as the Wind Generation Modeling Group, is working on wind and solar generation modeling for WECC.

An inverter is used to couple the PV array to an AC network. Figure 2 shows the topology of a specific type of three phase PV inverter. One of the control objectives is maximum power tracking, which means that the voltage across the capacitor is controlled such that the PV array operates at the maximum power point. The inverter also regulates ac current magnitude very fast, even during disturbances, to ensure that current and temperature limits of the switching elements in the power block are not exceeded. Inverters also have the capability to change power factor, within the current magnitude limits. With appropriate controls implemented, inverter-based reactive power capability could be used to achieve reactive power control objectives at the plant level. The integrated isolation transformer and filter reduce harmonic injection into the grid. Additional filtering may be applied at the DC side to reduce ripple effects, and at the inverter output to reduce high frequency electromagnetic emissions.

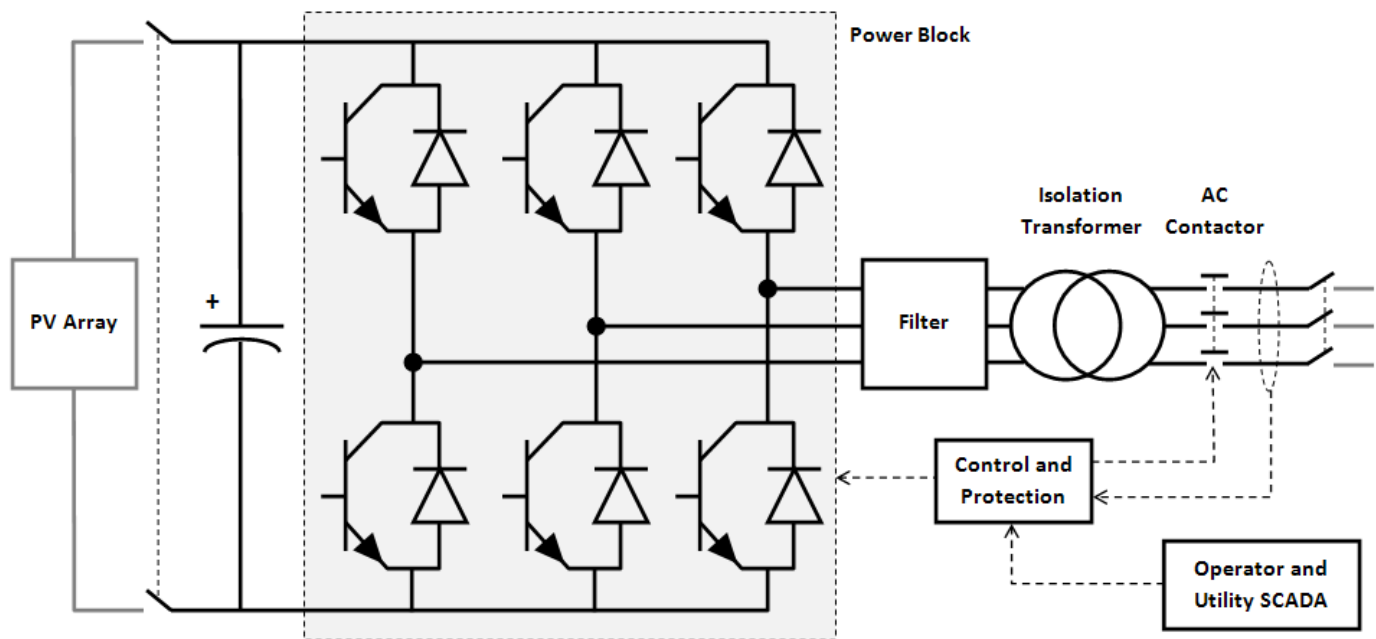

Figure 2 – Utility-scale three-phase PV inverter (left) and general topology (right)

The grid converter monitors the AC voltage and frequency to modulate converter behavior and disconnect the inverter from the grid when voltage and frequency tolerances are exceeded. The IEEE 1547-2003 standard defines voltage and frequency thresholds for residential and commercial PV systems and other distributed energy resources, as shown in Table 1. In addition, IEEE 1547 requires that distribution-connected PV inverters de-energize after faults on the Area EPS circuit² and prior to circuit reclosure. Inverters must “cease to energize” within 2 seconds of the formation of an electrical island (i.e., when a portion of the grid disconnects from the bulk system). This feature is commonly referred to as “anti-islanding”. PV inverters connected to the customer side of the meter are required to have certification that they comply with these and other safety and grid compatibility requirements. UL 1741 is an example of certification that addresses this issue.

² Area electric power system (EPS) refers to the portion of the distribution system that serves the premises where the PV system is located. This is typically a feeder or feeders served from the same unit substation.

Table 1 – IEEE 1547 protection thresholds

Voltage Range (% Nominal)	Max. Clearing Time (sec) *	Frequency Range (Hz)	Max. Clearing Time (sec)
$V < 50\%$	0.16	$f > 60.5$	0.16
$50\% \leq V < 88\%$	2.0	$f < 57.0$ *	0.16
$110\% < V < 120\%$	1.0	$59.8 < f < 57.0$ **	Adjustable (0.16 and 300)
$V \geq 120\%$	0.16		

(*) Maximum clearing times for DER ≤ 30 kW;
Default clearing times for DER > 30 kW

(*) 59.3 Hz if DER ≤ 30 kW
(**) For DER > 30 kW

Interconnection standards for central-station PV systems connected directly to the transmission (and sometimes distribution) grid are evolving and can vary considerably from the above. Currently, the NERC Integration of Variable Generation Task Force (IVGTF) is working on recommendations on various aspects of reliability standards applicable to PV and wind generation³.

2.2 PV Systems

PV systems are highly modular and can be designed for a wide range of applications, from small residential systems to utility-scale, transmission-connected power plants. Distribution-connected residential and commercial systems typically connect to the customer side of the meter at single phase (120/240V) or three-phase (208/480V). Typical residential systems are less than 10 kW and have a single inverter, while commercial systems can reach several MW and typically have multiple inverters. Power is injected into the grid at unity power factor. Residential and commercial systems are electrically separated from the transmission system by two transformer stages and equivalent line impedance. Figure 3 shows a large PV system.



Figure 3 - Portion of the Nellis AFB 14 MW PV system (distribution-connected).

³ More information can be found here: <http://www.nerc.com/filez/ivgtf.html>.

Central-station systems connect to the medium voltage distribution system or transmission system. Presently, the largest central-station PV system presently installed in the US is 25 MW, however, multiple systems in the 50 to 500 MW range are being proposed, and are considered as an integral part of future deployment scenarios. A typical central-station PV plant consists of several individual PV inverters tied to a medium voltage collector system (Figure 4). The nameplate rating of utility-scale inverter range from 100 kVA to 1000 kVA. They operate at low voltage (<600 Vac) output. A step-up transformer connects the inverters to the medium voltage system. Several inverters may be connected to a single pad-mounted transformer. PV plants as large as 14 MW have been connected directly to an existing distribution feeder, or to the unit station through a dedicated feeder. Larger PV plants would be transmission-connected. The design would consist of a collector system with one or more radial feeders, a dedicated medium voltage station and bulk transformer. An interconnection line would be needed unless the collector system station is adjacent to the interconnection point. Reactive power support at the interconnection point, to the extent that it is required, can be provided by the inverters, dedicated plant-level reactive power support equipment such as mechanically-switched capacitors, or a combination of both.

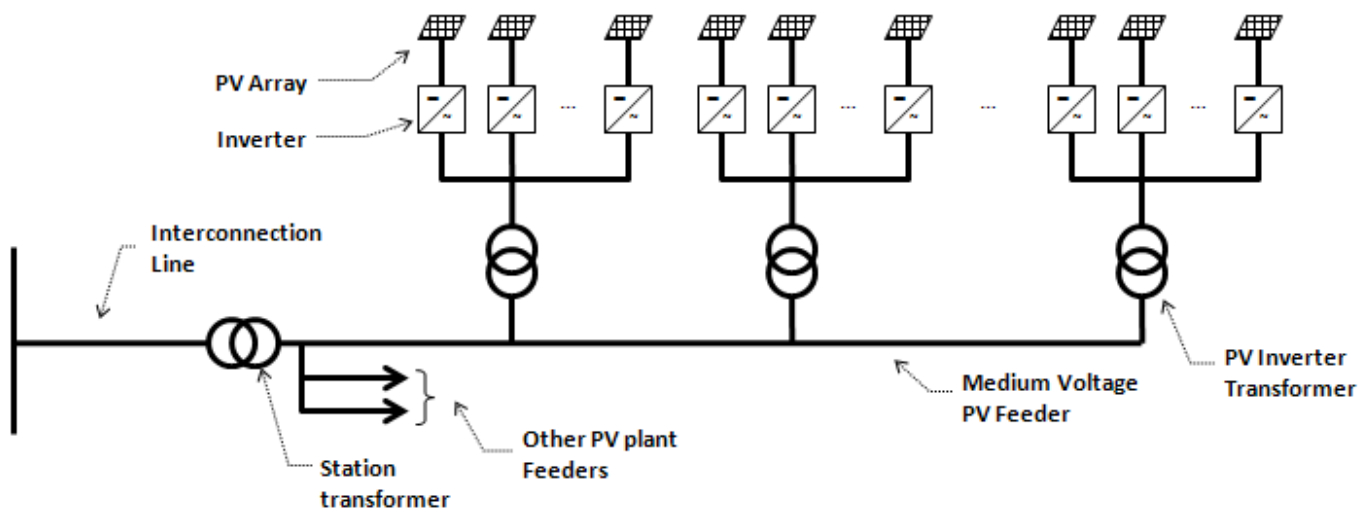

Figure 4 – Generic central-station PV plant topology

Energy storage is rarely installed in conjunction with grid-connected PV systems. Therefore, variations in irradiance are reflected into variations of PV plant output. In addition to the predictable seasonal and diurnal cycles, short-term irradiance variability also occurs as a result of cloud shadows moving across the PV array. Variability is a function of cloud characteristics (density, size, velocity, opacity, height) plant size and tracking method and physical separation between individual PV systems. Compared to irradiance measured at a single point, output variability of large PV plant or a collection of distributed PV systems varies much more slowly. A full discussion of variability is out of the scope of this guide. Significant work has recently been done in this area⁴.

⁴ For a more comprehensive discussion on PV output variability, refer to *Mills, et. al., "Understanding Variability and Uncertainty of Photovoltaics for Integration with the Electric Power System", eetd.lbl.gov/ea/emp/reports/lbnl-2855e.pdf*

3. Representation of PV Systems in Bulk System Studies

3.1 Central Station PV Systems

The WECC Data Preparation Manual⁵ states that single generating units 10 MVA or higher, or aggregated capacity of 20 MVA connected to the transmission system (60kV and above) through a step-up transformer(s) should be modeled as distinct generators in WECC base cases. It also states that collector-based system such as wind or solar plants connected to the transmission grid may be represented as an equivalent generator, low voltage to intermediate voltage transformer, equivalent collector circuit, and transformer, as recommended by REMTF's WECC Wind Power Plant Power Flow Modeling Guide⁶.

Because of similarities in the internal topology of central station photovoltaic (PV) plants and wind plants, the guidelines contained in this document are very similar to a previously issued guide for wind power plants. REMTF recommends the use of the single-machine equivalent representation shown in Figure 5 to model central-station PV plants in WECC base cases. This representation is also considered adequate for positive-sequence transient stability simulations at the bulk system level. If present, the interconnection transmission line, station transformer(s) and plant-level reactive compensation should be represented explicitly, according to established industry practice.

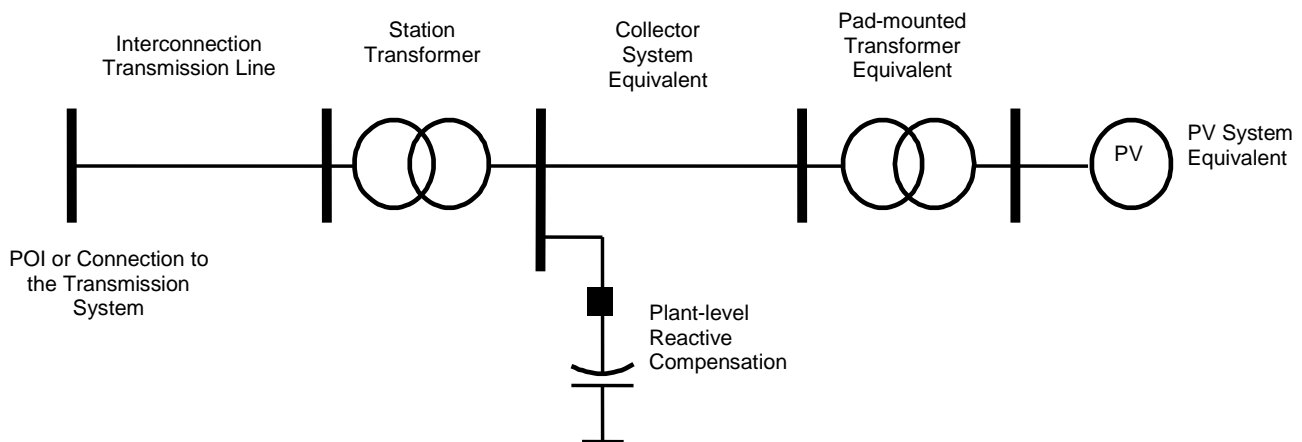

Figure 5 – Single-machine equivalent load flow representation

In this model, the equivalent generator represents the total generating capacity of all the inverters, the equivalent pad-mounted transformer represents the aggregate effect of all step-up transformers, and the equivalent collector system branch represents the aggregate effect of the PV plant collector system. With the proper model parameters, this model should approximate PV plant load flow characteristics at the interconnection point, collector system real and reactive losses and voltage profile at the terminals of the “average” inverter in the PV plant.

As with any other model, the single machine representation has some limitations. Due to collector system effects, terminal voltage of individual inverters could vary somewhat, especially in very large PV plants where the electrical distance between inverters may be significant. Inverters that are closest to the interconnection point may experience significantly different terminal voltage compared to inverters that are electrically farthest from the interconnection point. In actual operation, terminal voltage of some inverters may reach control or protection limits, resulting in different terminal

⁵ WECC Data Preparation Manual For Power Flow Base Cases and Dynamic Stability Data, August 2009, REV. 7

⁶ WECC Wind Power Plant Power Flow Modeling Guide Prepared by WECC Wind Generator Modeling Group May 2008

behavior, or tripping. During the design stage, or in special cases, it may be reasonable to use a more detailed representation of the collector system to capture these details. However this type of detail usually is not feasible for large-scale simulations.

The following guidelines should be considered to model each of the components of the PV plant single-machine equivalent representation.

Interconnection Transmission Line

Standard data includes nominal voltage, positive-sequence line parameters (impedance and charging) and line rating.

PV Plant Station Transformer

Transmission-connected PV plants require a station transformer. It should always be represented explicitly. Standard data includes transformer nominal voltage of each winding, impedance, tap ratios, regulated bus and set point, and ratings. Positive-sequence impedance for station transformers is in the range of 6% to 10%, and X/R ratio in the range of 20 to 50.

Plant Level Reactive Compensation

PV plants could have station fixed and/or switched capacitors installed at collector system. If present, shunt capacitors should be modeled as constant impedance devices in load flow, to capture voltage-squared effects. The WECC Data preparation Manual states that each switched capacitor should be modeled explicitly. Standard data includes nominal rating, impedance, and controlled device, if applicable. Operation of the shunt devices is coordinated with the plant-level reactive controller (see equivalent generator representation).

Equivalent Collector System

Central-station PV plants collector systems consist of one or more medium voltage underground feeders, as described in Figure 4. Factors considered in feeder design include cost, real power losses, and voltage performance. A typical design goal is to keep average real power losses below 1%. At full output, real power losses can be higher, as much as 2% to 4%. The collector system network is typically underground. For that reason, the equivalent collector system X/R ratio tends to be low compared to typical overhead circuits. The equivalent collector system impedance tends to be small compared to the station transformer impedance, but it not insignificant.

A simple method developed by NREL⁷ can be used to derive equivalent impedance (Z_{eq}) and equivalent susceptance (B_{eq}) of a collector system consisting of radial elements. The computation is as follows:

$$Z_{eq} = R_{eq} + jX_{eq} = \frac{\sum_{i=1}^I Z_i n_i^2}{N^2},$$

$$B_{eq} = \sum_{i=1}^I B_i,$$

⁷ E. Muljadi, A. Ellis, et al, "Equivalencing the Collector System of a Large Wind Power Plant", IEEE Power Engineering Society Annual Conference, Montreal, Quebec, June 12-16, 2006.

where I is total number of branches in the collector system, Z_i and n_i are the impedance ($R_i + jX_i$) for i^{th} branch, and N is the total number of inverters in the PV plant. Branch impedance data can be obtained from collector system design (conductor schedule) for the project. As stated before, the equivalent impedance computed in this manner approximates real and reactive losses seen by the “average inverter” in the PV plant. This calculation can be easily implemented in a spreadsheet. Figure 6 shows a simple example with nine branches ($I = 9$), and 21 inverters ($N = 21$). The corresponding calculations are shown in Table 2. In this example, the inverters are 7 clusters of 3 inverters. In general, larger PV power plants would have lower Z_{eq} and higher B_{eq} considering that more parallel feeders would be required.

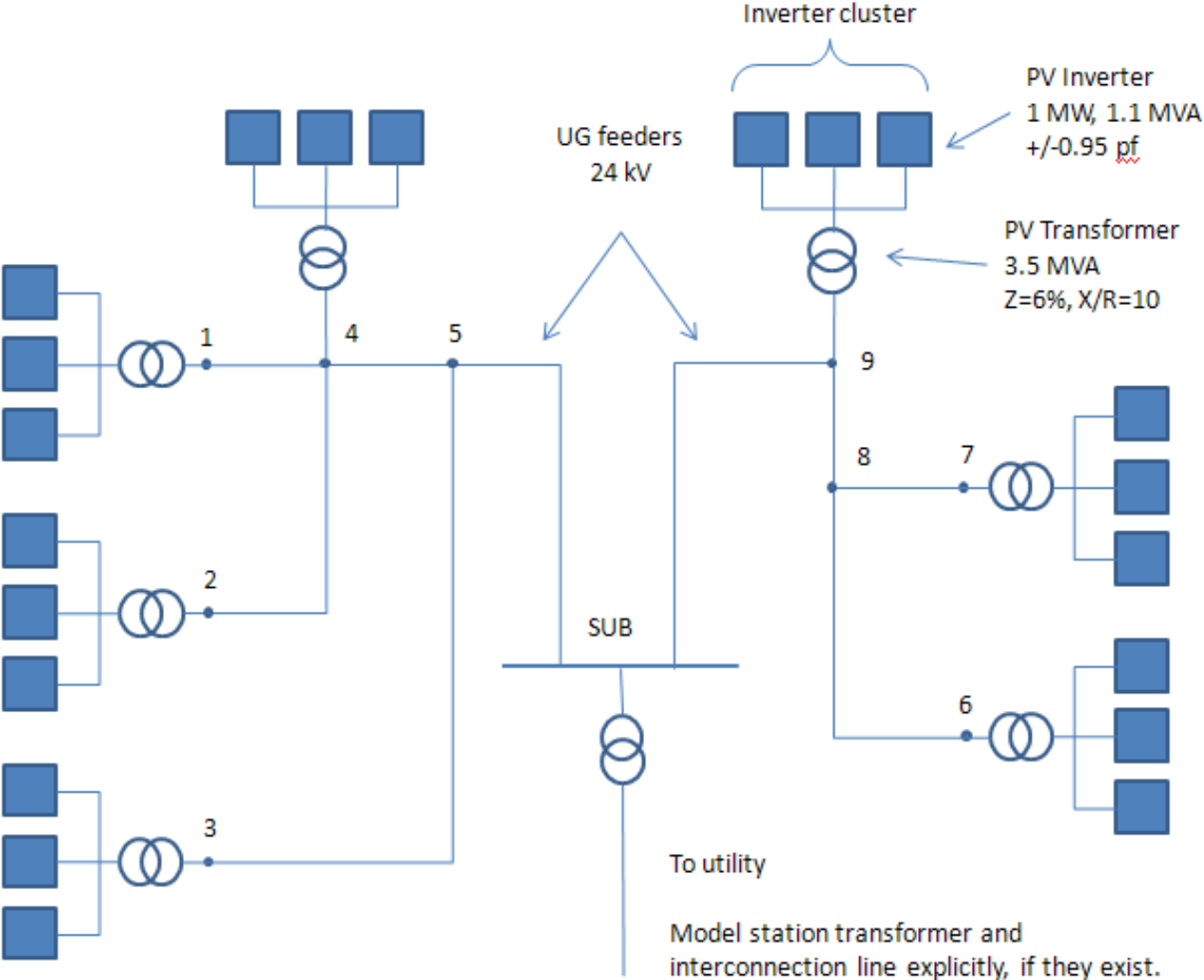

Figure 6 – Sample Utility-Scale PV plant topology

Table 2 - Computation of collector system equivalent parameters for the sample system in Figure 6

From	To	R	X	B	n	R n ²	X n ²
1	4	0.03682	0.00701	0.000000691	3	0.33136	0.06307
2	4	0.02455	0.00467	0.000001036	3	0.22091	0.04205
4	5	0.02455	0.00467	0.000001036	9	1.98816	0.37843
3	5	0.02557	0.02116	0.000000235	3	0.23016	0.19042
5	SUB	0.02557	0.02116	0.000000235	12	3.68251	3.04673
6	8	0.03747	0.00868	0.000000561	3	0.33726	0.07809
7	8	0.02455	0.00467	0.000001036	3	0.22091	0.04205
8	9	0.02109	0.02501	0.000000199	6	0.75925	0.90025
9	SUB	0.02109	0.02501	0.000000199	9	1.70831	2.02555

RESULTS	
Partial R sum	9.4788
Partial X sum	6.7666
N	21
Collector System Equivalent (Same units as R, X & B data)	
Req	0.021494 pu
Xeq	0.015344 pu
Beq	0.000005 pu

Equivalent PV Plant Step Up

A PV large plant has several pad-mounted transformers, each connected to one or more PV inverters. Assuming that all step-up transformers are identical, and each connects to the same number of inverters, the per-unit equivalent impedance (Z_{Teq}) and the equivalent MVA rating (MVA_{Teq}) can be computed as follows:

$$Z_{Teq} = Z_T$$

$$MVA_{Teq} = N \times MVA_T$$

In these equations, Z_T is the impedance of one transformer on its own MVA base (MVA_T). For the example system discussed above, the equivalent transformer impedance would be 6% on a 21 MVA base (7 X 3 MVA), with an X/R ratio of 10. If there are different transformer sizes or a different number of inverters are connected to each transformer, the method shown in Table 2 can be applied to calculation of the equivalent transformer impedance. Step-up transformers associated with utility-scale PV plants are in the range of 500 kVA to 2 MVA, and have impedance of approximately 6% on the transformer MVA base, with X/R ratio of about 8.

Equivalent PV Generator Representation

For load flow simulations, the equivalent PV generator should be represented as a standard generator, as opposed to a negative load. Active power level and reactive power capability must be specified according to the guidelines below.

- **Active Power Output Level**

PV plant output varies as a function of solar input and, to a lesser extent, temperature. Typically, PV plants are designed to achieve full output for several hours of the day under clear sky conditions. The real power level assumed for the PV plant depends on the purpose of the study. In the context of an interconnection study, a PV plant would be modeled a full output. For other studies, PV plants may be modeled at partial output or zero output. For instance, WECC off-peak cases correspond to night-time periods, when PV output is zero. Heavy summer scenarios typically correspond to mid afternoon peal load periods, when PV is likely to be near 100% of output. For regional transmission planning studies, it is recommended that the power level be established based on the average expected output level during the time frame of interest.

- **Reactive Power Capability**

Interconnection requirements and performance standards addressing reactive power capability from large PV systems are still evolving. Distribution-connected PV systems are generally operated at unity power factor over their entire active power output range. Most inverters designed for residential and commercial applications are not sized to provide any reactive current at full output. However, PV inverters used in utility-scale PV systems often have the capability to provide reactive support at full active power or at partial output. The reactive power capability could be higher at lower active output levels, depending on inverter current limits and depending on grid voltage conditions. The reactive capability curves for inverters differ from those of synchronous machines because they are normally limited by internal voltage and current constraints. Inverters are typically designed for operation from 90% to 110% of rated terminal voltage, and these voltage limits greatly affect the actual reactive power capability. When terminal voltage is 110%, no additional reactive power can be injected into the grid. As stated previously, interconnection standards for PV systems are evolving, and reactive power capability is one of the key areas of discussion. However, some interconnection standards being applied to transmission-connected PV describe reactive capability requirements as a “triangular”, “rectangular” or similar reactive capability characteristic (Figure 7).

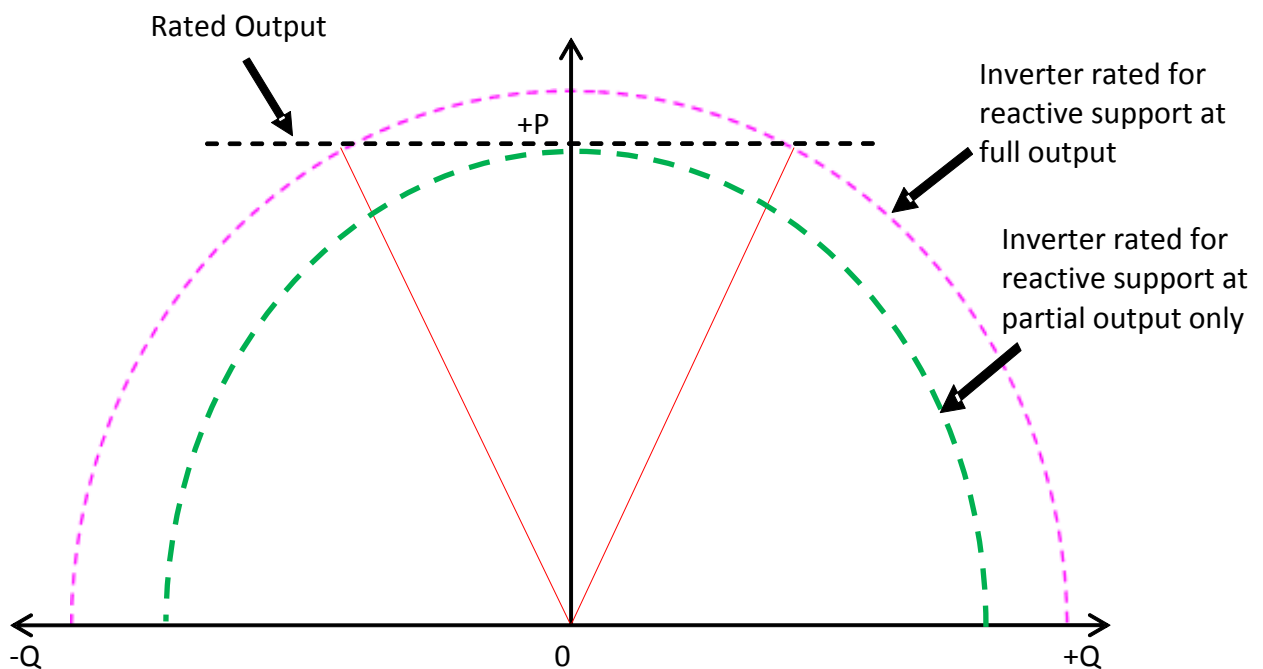

Figure 7 – Example of inverter reactive capability curves and interconnection requirements (triangular) at nominal voltage

These reactive curves are generally valid for nominal voltage only, considering the terminal voltage limits discussed above. It is technically possible to design PV inverters to provide reactive support even if solar input is zero, much like a STATCOM. At the plant level, it should be taken into account that a portion of the inverters in the plant may be turned off at low power output, resulting in a reduction of reactive capability.

When required, the power factor of individual inverters can be adjusted via a plant-level reactive controller to meet operating requirements at the point of interconnection⁸. Several control modes are possible:

- **Closed-loop voltage control** - Maintain voltage schedule within the reactive power capability of the PV plant, over a certain range of real power output. A small voltage hysteresis or dead band may be appropriate in some situations. For instance, the requirement may be to regulate voltage at the interconnection point within 1% or 2% of schedule.
- **Voltage droop control** – Increase or decrease reactive power output linearly, as a function of voltage. This type of control allows the PV plant to provide voltage support while avoiding large reactive power swings that a small PV plant would see when connected to a relatively strong transmission system. A small dead band may be implemented.
- **Power factor control** - Maintain power factor at the interconnection point close to a specified level. For instance, the requirement may be to maintain power factor between 0.98 lead and unity at the interconnection point.
- **Reactive power control** - Maintain reactive power flow within some specified limits. For instance, the requirement may be to limit reactive power flow at the interconnection point to 5 or 10 MVar, in either direction.

Representation of reactive power capability of the equivalent inverter depends on the reactive range of the inverters, and how that range is utilized in operations. For example, the equivalent generator for the sample system shown in Figure 5 would have a nameplate rating of 21 MW (21×1 MW) and 21.21 MVA (21×1.1 MVA). If the inverters participate in steady-state voltage control, then the equivalent generator should be modeled with a reactive range of +/- 0.95 power factor, which corresponds to setting Q_{min} and Q_{max} of -6.9 MVar and +6.9 MVar, respectively. If the inverters operate at a fixed power factor, then the equivalent generator should have $Q_{min} = Q_{max}$ at the corresponding power factor level. At an output level below rated, the reactive limits should be adjusted according to the inverter reactive capability that is programmed into the controls, and the effect of system voltage.

3.1 Representation of Distribution-Connected PV Systems

In some ways, representation of distribution-connected PV systems in bulk system studies is more challenging. In WECC base cases, the distribution system is not typically represented and the load, along with embedded distributed generation, is typically lumped at the transmission level. There is increasing industry consensus that distributed generation should be represented more explicitly to the extent that the penetration level is sufficiently high to affect bulk system performance. Representing PV generation and other distributed generation explicitly would allow for proper load scaling and would give planners the ability to account for existing and emerging performance standards applicable to distributed generation, including anti-islanding, voltage tolerance envelope and reconnection, and reactive support, which may be of interest to study future deployment scenarios. In general, distribution-connected PV systems should be represented in bulk system studies to the extent that the aggregate generation has the potential to affect grid reliability and compliance with NERC system performance criteria at the local level. In this regard, the present version of the WECC Data

⁸ The plant level controller also coordinates operation of the switched capacitors, if present

Preparation Manual⁹ states that, when aggregated generation exceeds 10 MVA at any load bus, it should not be netted. Further, the WECC Data Preparation Manual states that total netted generation in an area should not exceed five percent of the area total generation.

The following REMTF technical recommendations apply to modeling of PV systems when the amount of PV generation exceeds the threshold established by the WECC Data Preparation Manual, as amended. In some urban areas, significant generation capacity being developed in the form of large commercial-scale PV systems. Based in their size and their ability to potentially contribute to steady-state reactive power support, it is recommended that these systems be represented with a discrete lumped model with an equivalent LTC transformer and equivalent series impedance representing the impedance of the feeder, service transformer, and secondary network. A similar approach could be used for high penetration residential PV systems. The goal should be to capture the effect of reactive support as well as the voltage tolerance characteristics of PV systems in steady-state simulations, particularly voltage stability. While load modeling is out of the scope of this guide, the importance of properly representing the load, especially its voltage dependency, should be noted. In general, it would be good modeling practice to represent the load behind an equivalent feeder impedance, and use a ZIP or other suitable model to capture the voltage dependency. As stated before, the WECC REMTF is currently working on recommendations for dynamic simulation of transmission-connected and distribution-connected of PV system. Dynamic modeling considerations may affect how distribution-connected PV systems are represented in load flow. The recommended load flow representation for high penetration PV scenarios is shown in Figure 8. Note that the load was moved to the low voltage bus as well.

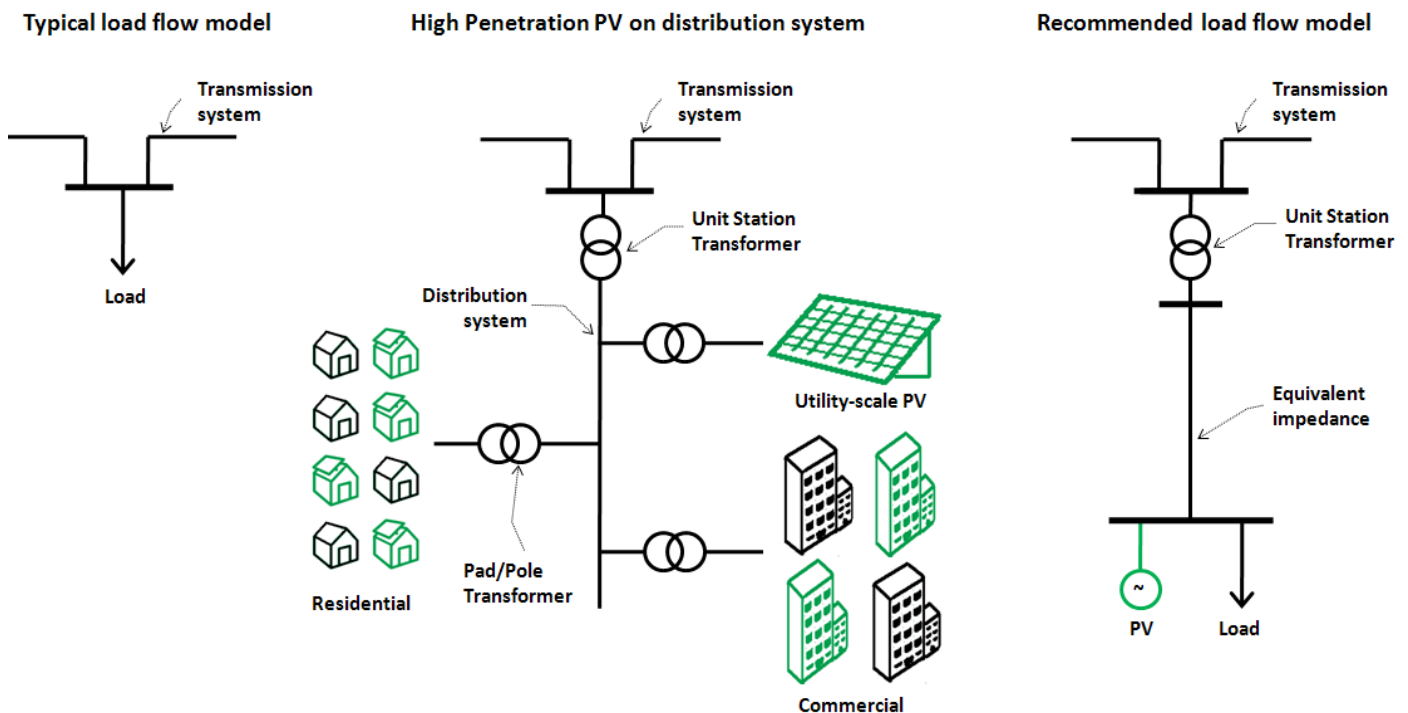

Figure 8 - Recommended load flow representation for study of high-penetration PV scenarios

⁹ WECC Data Preparation Manual For Power Flow Base Cases and Dynamic Stability Data, REV. 7, System Review Work Group, Technical Studies Subcommittee, August 2009. URL: <http://www.wecc.biz/committees/StandingCommittees/PCC/TSS/SRWG/Shared%20Documents/Data%20Preparation%20Manual%20V7.pdf>

Typical load flow data for the equivalent distribution feeder is shown in Table 3 below. Transformer impedances are on the transformer self-cooled MVA base, which should be appropriate for the amount of load served. The feeder impedance is on 100 MVA, 12.5 kV base. The feeder impedance data should be adjusted depending on the load level to obtain a reasonable voltage drop from the station transformer secondary to the typical utilization point, or approximately three percent.

Table 3 - Suggested data for distribution system equivalent

	R, pu	X, pu
Station transformer impedance, pu on transformer self-cooled MVA base	0	0.1
Equivalent feeder, service transformer and secondary impedance, pu on 100 MVA, 12.5 kV base	0.1	0.1

4. Modeling during post transient power flows

Modeling of PV generation and reactive compensation components should be consistent with WECC post-transient methodology. Control devices that can complete switching or operation within 3 minutes (e.g., SVCs, STATCOMS and shunts under automatic control) should not be blocked. Devices that require operator action should be blocked. The equivalent WPP generator should have the Load Flag set to “1” to reflect the fact that the output should not change during a governor power flow.

5. Model Validation

Single-machine equivalent model parameters can be derived from preliminary data, as discussed in this guide. Preliminary data should be replaced with as-built data when such data becomes available, certainly after commissioning. Load flow model data, particularly reactive power capability, should be validated from time to time by direct test or with actual operating data, consistent with WECC and NERC requirements and methodologies. As of the date this guide was written, specific testing and model validation guidelines for PV plant have not been adopted for use in WECC.

APPENDIX A SAMPLE PV POWER PLANT DATA REQUEST

Note: This document has been adapted to PV applications from the WECC Wind Power Plant Power Flow Modeling Guidelines¹⁰ dated May 2008. The data provider should refer to this document for background related to the specifics of this data request:

1. **One-Line Diagram.** This should be similar to Figure 1 below.

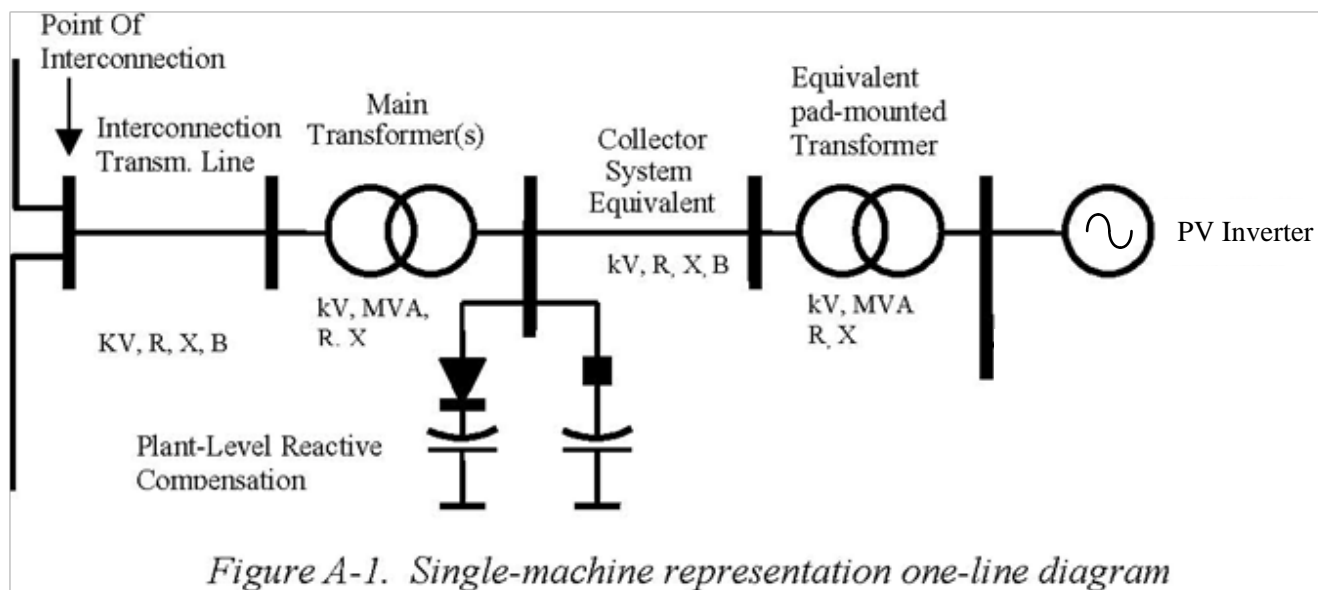

2. **Interconnection Transmission Line.**

- Point of Interconnection (substation or transmission line name): _____
- Line voltage = _____ kV
- R = _____ ohm or _____ pu on 100 MVA and line kV base (positive sequence)
- X = _____ ohm or _____ pu on 100 MVA and line kV base (positive sequence)
- B = _____ μ F or _____ pu on 100 MVA and line kV base (positive sequence)

3. **Station Transformer.** (Note: If there are multiple transformers, data for each transformer should be provided)

- Rating (ONAN/ONAF/ONAF): _____/_____/_____ MVA
- Nominal Voltage for each winding (Low /High /Tertiary): _____/_____/_____ kV
- Available taps: _____ (indicate fixed or with LTC), Operating Tap: _____
- Positive sequence Z_{HL} : _____%, _____X/R on transformer self-cooled (ONAN) MVA

¹⁰ <http://www.wecc.biz/library/WECC Documents/Documents for Generators/Generator Testing Program/Wind Generator Power Flow Modeling Guide.pdf>

4. Collector System Equivalent Model. This can be found by applying the equivalencing methodology described in Section 3.4; otherwise, typical values can be used.

- Collector system voltage = _____ kV
- R = _____ ohm or _____ pu on 100 MVA and collector kV base (positive sequence)
- X = _____ ohm or _____ pu on 100 MVA and collector kV base (positive sequence)
- B = _____ μ F or _____ pu on 100 MVA and collector kV base (positive sequence)

5. Inverter Step-Up Transformer. Note: These are typically two-winding air-cooled transformers. If the proposed project contains different types or sizes of step-up transformers, please provide data for each type.

- Rating: _____ MVA
- Nominal voltage for each winding (Low /High): _____/_____kV
- Available taps: _____ (indicate fixed or with LTC), Operating Tap: _____
- Positive sequence impedance (Z1) _____%, _____X/R on transformer self-cooled MVA

6. Inverter and PV Module Data.

- Number of Inverters: _____
- Nameplate Rating (each Inverter): _____/_____ kW/kVA
- Describe reactive capability as a function of voltage: _____
- Inverter Manufacturer and Model #: _____
- PV Module Manufacturer and Model #: _____
- [Note: This section would also request completed PSLF or PSS/E data sheets for the generic PV library model(s) once they are available.]

7. Plant Reactive Power Compensation. Provide the following information for plant-level reactive compensation, if applicable:

- Individual shunt capacitor and size of each: _____X_____ MVA
 - Dynamic reactive control device, (SVC, STATCOM): _____
 - Control range _____ MVar (lead and lag)
 - Control mode (e.g., voltage, power factor, reactive power): _____
 - Regulation point _____
 - Describe the overall reactive power control strategy: _____
-