



Document name	WECC Energy Storage System Model – Phase II
Category	<input type="checkbox"/> Regional Reliability Standard <input type="checkbox"/> Regional Criteria <input type="checkbox"/> Policy <input type="checkbox"/> Guideline <input checked="" type="checkbox"/> Report or other <input type="checkbox"/> Charter
Document date	April 20, 2015
Adopted/approved by	MVWG
Date adopted/approved	March 18, 2015
Custodian (entity responsible for maintenance and upkeep)	M&VWG
Stored/filed	Physical location: Web URL:
Previous name/number	
Status	<input checked="" type="checkbox"/> in effect <input type="checkbox"/> usable, minor formatting/editing required <input type="checkbox"/> modification needed <input type="checkbox"/> superseded by _____ <input type="checkbox"/> other _____ <input type="checkbox"/> obsolete/archived)

TO: WECC REMTF
FROM: POUYAN POURBEIK, EPRI; PPOURBEIK@EPRI.COM
SUBJECT: SIMPLE MODEL SPECIFICATION FOR BATTERY ENERGY STORAGE SYSTEM
DATE: 1/15/15 (REVISED 2/25/15; 3/6/15; 3/18/15 REV3)
CC: EPRI P173.003

Background:

For the past few years extensive work was done in the development, validation and release of a new set of simple generic models for the simulation of renewable energy systems in positive sequence power simulation tools for the purpose of large scale stability simulations. This work was done through the WECC [1]. Some of the details on testing and validation of the models may be found in [2] and [3].

What is presented in this brief memo is the specification for a new module to be added to the existing set of renewable energy system model set described in [1]. With this addition of this module, the user will be able to emulate, for the purposes of stability studies, the dynamic behavior of battery energy storage systems (BESS).

The proposed model is based on [4], with subsequent additional and changes made based on recommendations and suggestions after several discussion both with WECC REMTF Adhoc group on BESS modeling¹ and several EPRI funders². Following these discussions the agreed to model, at this point, is documented herein.

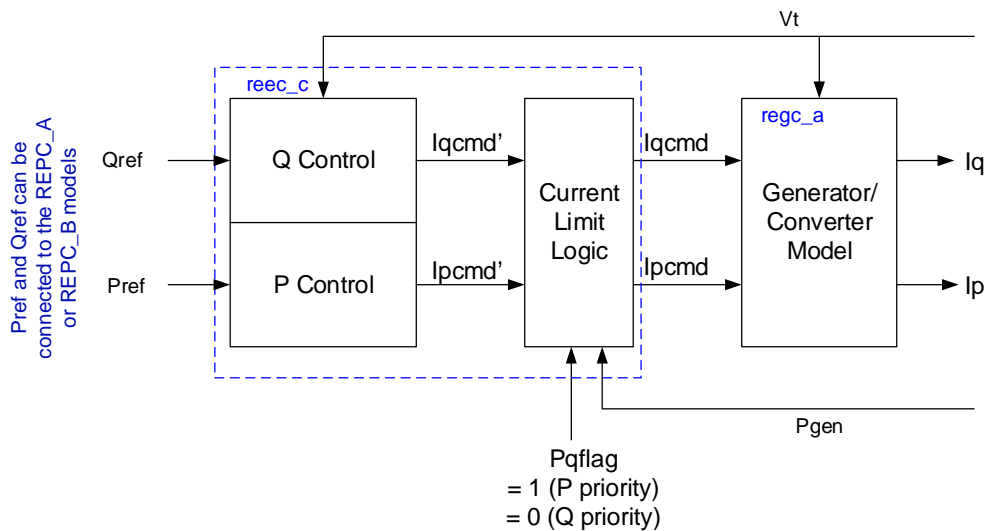

Figure 1: Overall BESS model

¹ WECC REMTF Adhoc Group on BESS modeling: Nagy Abed, Hassan Baklou, Abe Ellis, Roberto Favela, Bo Gong, Shengli Huang, Irina Green, Yuriy Kazachkov, Ronnie Lau, Edwin Liu, B. T. Phan, P. Pourbeik, Juan Sanchez-Gasca, Jay Senthil, Hari Singh, Spencer Tacke, James Weber, Jun Wen, Stephen Williams, Xiaokang Xu

² Peter Belkin, Bill Quaintance, Pat Quinn, George Stefopoulos

The REEC_C Model:

The 2nd generation wind turbine generator models, which form the core of the renewable energy systems models, [1] are in fact a series of modules that can be connected together in various combinations to yield a type 3 wind turbine generator (WTG), a type 4 WTG or a photovoltaic (PV) system. Thus, the proposal here is to add another module to that set and to call it *REEC_C* (renewable energy electrical controller C). This new module, when incorporated with the *REGC_A* model can then represent a battery energy storage (BES) unit. Furthermore, either the *REPC_A* plant controller, or the *REPC_B* plant controller (currently under development [5]), can also be used with these models to allow one to emulate various functionalities such as frequency regulation etc. Figure 2 shows the block diagram of the *REEC_C* model.

The *REEC_C* model is essential based on the *REEC_A* model with the following changes/additions made (shows in red in the figure):

1. Removing some of the wind specific features. Namely, the following parameters, and associated logic and dynamics, have been removed: I_{qfr} , T_{hld} , T_{hld2} and V_{ref}
2. I_{pmin} – the active current lower limit should take on the negative value of I_{pmax} to allow for charging as well as discharging.
3. SOC_{ini} – this is the initial state of charge on the battery and is a user entered value. It should be in per unit; 1 per unit means fully charged and 0 per unit means fully discharged³.
4. SOC_{max} – this is the maximum allowable state of charge. By definition the maximum value would be 1, however, it may be set to smaller values (e.g. 0.8) to represent manufacturer requirements that the BESS always remain at or below a certain charging level (e.g. 80%).
5. SOC_{min} – this is the minimum allowable state of charge. By definition the minimum value would be 0, however, it may be set to larger values (e.g. 0.2) to represent manufacturer requirements that the BESS always remain at or above a certain charging level (e.g. 20%).
6. T – this is the discharge time in units of seconds.
7. $Paux$ – this is an auxiliary input for interfacing with supplemental models, e.g. power oscillation damping control, etc.

The current limit logic is the same as *REEC_A*, with of course the addition that $I_{pmin} = -I_{pmax}$. All other aspects of the model are identical to the *REEC_A* model.

The *SOC* (i.e. $SOC_{ini} - s7$) should also be an output of the model which can be both plotted and accessed by the user (e.g. for feedback control in user written supplemental models).

Assumptions:

There are several clear assumptions inherent in this proposed model:

- The battery chemistry can be ignored and we are primarily interested in solid state batteries. Lead acid batteries, when they reach close to their discharge levels, will have some diminished output capacity and so the power limits can be dynamic. This is generally not true of solid state batteries, such as Lithium-Ion.
- We are neglecting the details of the dc dynamics.

³ In the original proposed specification the variables were based on charge time remaining. They have been redefined here based on 'state of charge'. This makes no difference or change to the model; it is simply a matter of definition and preference. The consensus among the REMTF Adhoc group was that they preferred a state-of-charge definition.

- The model is a positive sequence model similarly intended as all the previous models developed under WECC REMTF.

Example of Model Parameterization:

Let us consider a hypothetical (but reasonable) example. Let us assume we have a BESS that is rated 40 MVA, with an energy rating of 30 MWh for 4 hours. Also, let us assume that when in operation the BESS is required by the vendor to always be in a state of charge between 20 to 80%, with the same charging rate (i.e. 4 hours).

Then,

$$SOC_{max} = 0.8$$

$$SOC_{min} = 0.2$$

Total energy = $30 \times 4 = 120$ MJ, thus in operation it can go from 0.8×120 (96 MJ) to 0.2×120 (24 MJ), which means that the maximum output would be $(96 - 24) / 4 = 18$ MWh for 4 hours.

Therefore,

$$T = ((18/30) \times (60 \times 60 \times 4)) / (0.8 - 0.2) = 14,400$$

$$P_{max} = 18/30 = 0.6$$

$$P_{min} = - P_{max} = -0.6$$

$$I_{max} \text{ (see [1] for details)} = 40/30 = 1.33$$

Model MVA = 30 MVA so that SOC_{max} and SOC_{min} correspond to 80% and 20%, respectively.

All other parameters would be set per the vendor data.

Initial Conceptual Testing:

An initial prototype model was developed by EPRI in MATLAB®. A few simulations were run to prove that the concept works. An illustrative simulation was provided in the first release of this memo and discussed in the various forums (see Appendix 1). Subsequently, after releasing the initial model specification, all the major commercial software vendors in WECC also implemented the model as a beta version and tested it and were able to get the exact same response as shown in the illustrative example. This is shown in Figure 3 (see Appendix 1 for more details).

Model Validation:

EPRI, through an NDA under a separate project, was able to obtain actual field data for the operation of a pilot demonstration project for an actual BESS unit in operation in the US.

The battery is a 36 MVA unit capable of 24 MWh for 3 hours. The vendor requires that it be always operated in a state of charge between 20 to 80%, thus allowing the unit to actually deliver 14.4 MWh for 3 hours.

We thus simulated a sequence of events for which the actual response of the battery was recorded using our (EPRI) prototype model. The results are shown in Figure 4.

As can be seen the fit is excellent and given the fact that the beta version of the model, as implemented in the commercial tools give perfect correspondence among the tools and with the illustrative example in Figure 3, we have every confidence that it will also match for this example.

Model Usage:

It should be noted that the immediate intended usage of this model is for stability studies, which typical span over 10 to 30 seconds. Thus, in reality the dynamics of the charging and discharging for large BESS systems (like the one show in the validation case here, which can charge/discharge for 4 hrs) is irrelevant. This is because the charging/discharging time is orders of magnitude larger than the simulation time. As such, in the interim the *REEC_A* + *REGC_A* models can be used to represent a BESS during its discharging mode. However, since $I_{pmin} = 0$ by default for the *REEC_A* model, discharging cannot be represented until this new model is officially released. As discussed at the last REMTF Adhoc group meeting, it is not prudent to change the existing *REEC_A* model to allow for a negative value of I_{pmin} for two reasons:

1. Issues related to model versioning and having to formally approve the new model, and
2. The high probability of misuse of the *REEC_A* model for wind and PV generating units (i.e. inadvertently setting I_{pmin} to less and zero and having a wind or PV plant absorbing power during a simulation, which is absurd, and it going unnoticed).

Conclusion:

It is recommended that WECC approve this specification and model so that the commercial software vendors may finalize the implementation and release of the model in their respective next release of their programs.

References:

[1] *WECC Second Generation Wind Turbine Models, January 23, 2014.*

https://www.wecc.biz/_layouts/15/WopiFrame.aspx?sourcedoc=/Reliability/WECC%20Second%20Generation%20Wind%20Turbine%20Models%20012314.pdf&action=default&DefaultItemOpen=1

[2] Technical Update – Generic Model for Wind Turbine Generators and Photovoltaic Generation and Model Validation. EPRI, Palo Alto, CA: 2013. Product ID# 3002001002. (<http://www.epri.com/abstracts/Pages/ProductAbstract.aspx?ProductId=00000003002001002&Mode=download>)

[3] A. Ellis, P. Pourbeik, J.J. Sanchez-Gasca, J. Senthil and J. Weber, “Generic Wind Turbine Generator Models for WECC – A Second Status Report” Accepted for publication at the IEEE PES General Meeting 2015, paper 15PESGM0126, Denver, CO, USA

[4] P. Pourbeik, “*Proposal for Simple Battery Energy Storage Model*”, PPT presentation slides; prepared on 1/13/15.

[5] P. Pourbeik, “Model Specification for High-Level Plant Controller”, dated 11/25/14 (revised 1/6/15); issued to REMTF Adhoc group; EPRI P173.003 and IEC TC88 WG27.

Appendix 1: Illustrative Simulation

Figure 3 shows an “illustrative” simulation simply to demonstrate the functionality of the model. The BESS starts out with the initial power output (determined from the powerflow solution in a full system model) being $P_{gen} = 0$. The initial state of charge is assumed to be $SOC_{ini} = 0.5$. The total charge is set to be $SOC_{max} = 1$ and the minimum charge to $SOC_{min} = 0$. The time constant $T = 20$ seconds. At time = 1 second the power reference P_{ref} is stepped up to 0.5 pu ($dP_{max}=dP_{min} = 99$). Then at time = 10 seconds P_{ref} is stepped down to -0.5 pu, and at time = 20 seconds it is stepped up to 1 pu. As one can see the BESS first discharges at the correct level (0.5 pu) up to 10 seconds, then charges from 10 to 20 seconds at 0.5 pu and finally discharges from 20 seconds onwards at a rate of 1 pu, until it runs out of charge at 31 seconds and thus shuts down. Simultaneously, a voltage dip was imposed between 10 to 15 seconds and 42 and 47 seconds. We can clearly see that the voltage dip invokes a reactive response from the reactive power control loop, which is essentially independent of the active power, as one would expect.

Appendix 2: Model Initialization

The initialization of this model is identical with *REEC_A* [1]. The only additional state is state $s7$. Upon initialization $s7$ should be set to zero. However, the model may have an initial output (P_{gen}) from powerflow that is non-zero (e.g. BESS is charging or discharging from the onset of the simulation). In that case $ds7$ will be non-zero and the state will start moving from the very beginning of the simulation. This of course is not a problem, since the output of the BESS is not affected until the state of charge hits a limit. Furthermore, this is a model of a physical process – the charging and discharging of a battery – which therefore can be charging or discharging from the very start of the simulation (i.e. $ds7$ is non-zero).

The program should, however, check that the following conditions are met upon initialization:

1. $P_{min} \leq P_{gen} \leq P_{max}$
2. $SOC_{min} \leq SOC_{ini} \leq SOC_{max}$

If these conditions are not met, then the program should notify the user.

Warning!!
 Extreme care should be taken in coordinating the parameters dbd1, dbd2 and Vdip, Vup so as not to have an unintentional response from the reactive power injection control loop.

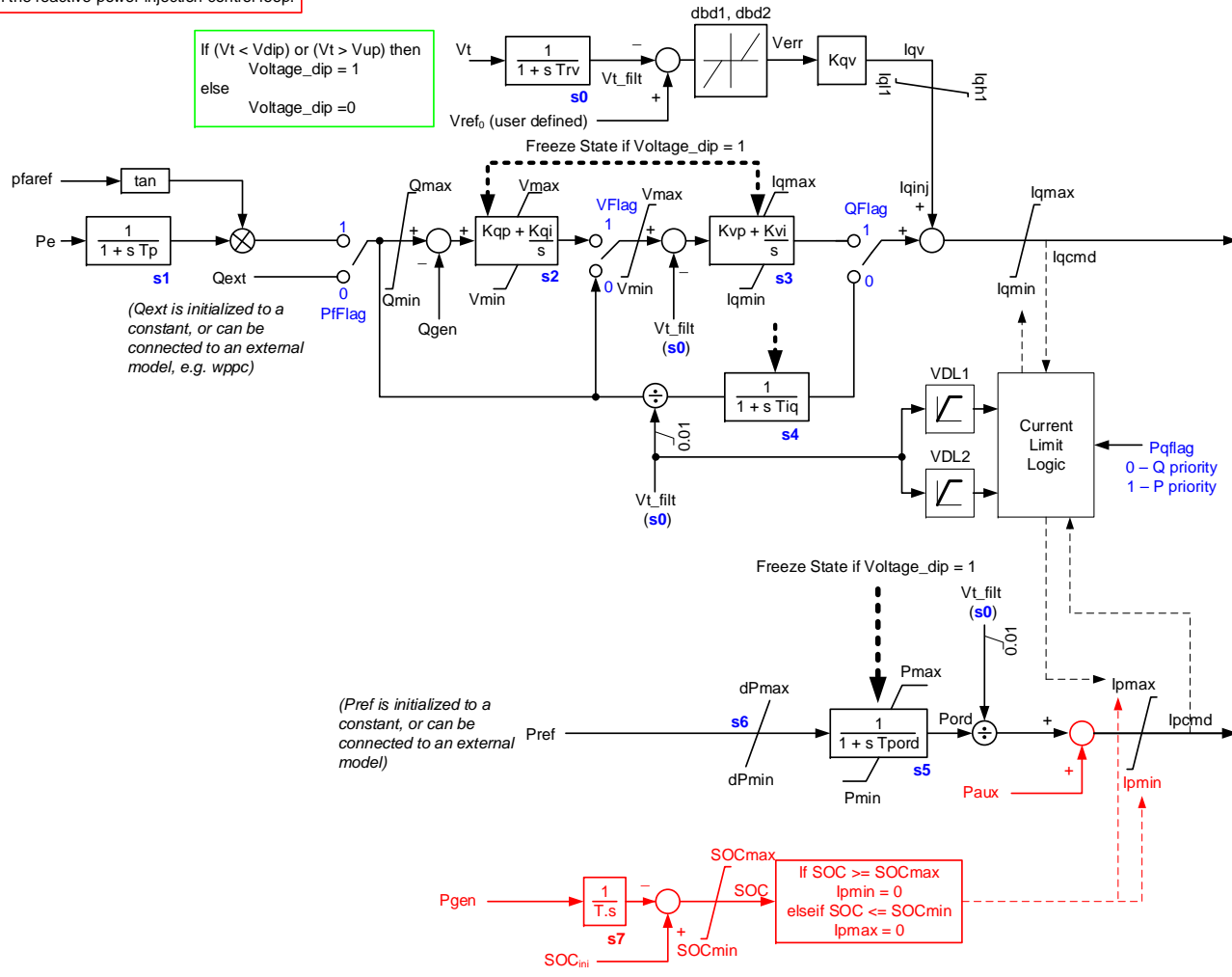

Figure 2: Proposed Renewable Energy Electrical Controller C for representing BES – REEC_C.

Together . . . Shaping the Future of Electricity

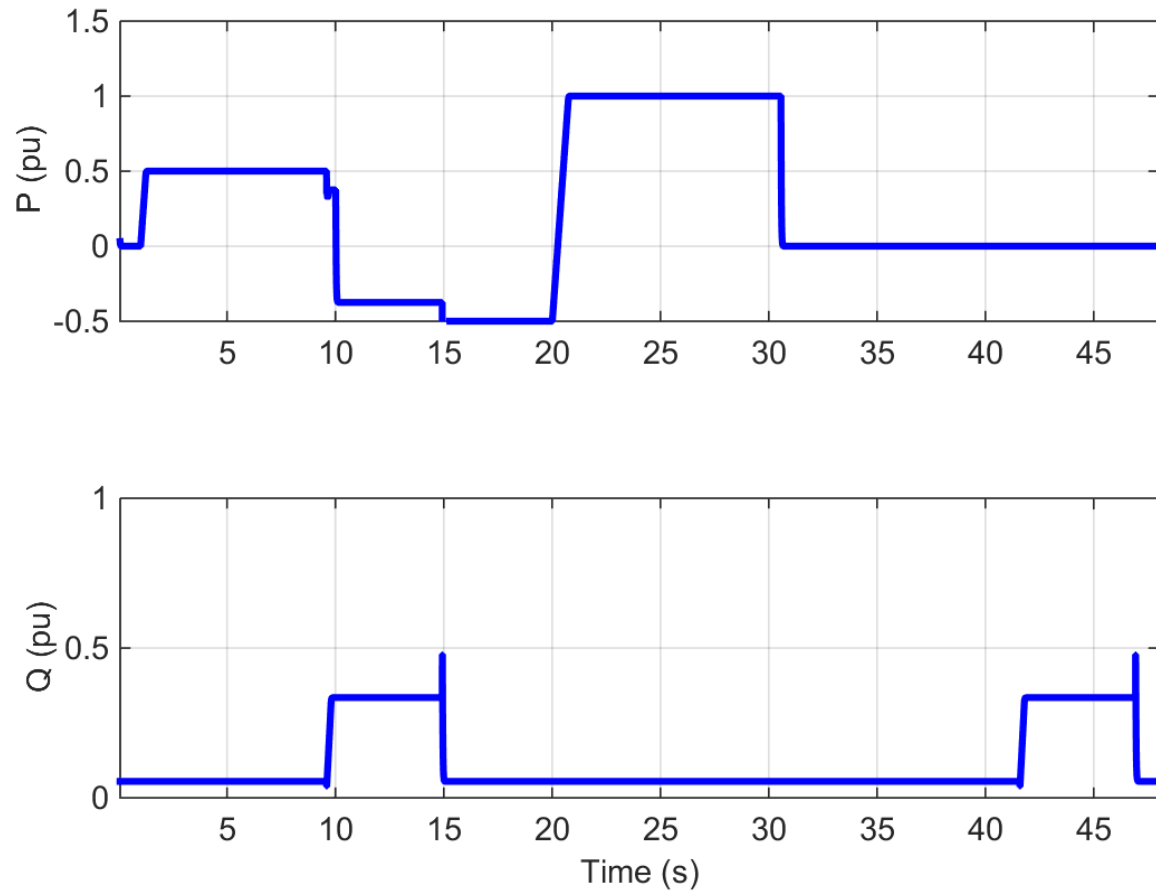

Figure 3: Illustrative simulation.

Together . . . Shaping the Future of Electricity

Knoxville Office

942 Corridor Park Blvd., Knoxville, TN 37932 USA • 865.218.8000 • Fax 865.218.8001 • Customer Service 800.313.3774 • www.epri.com

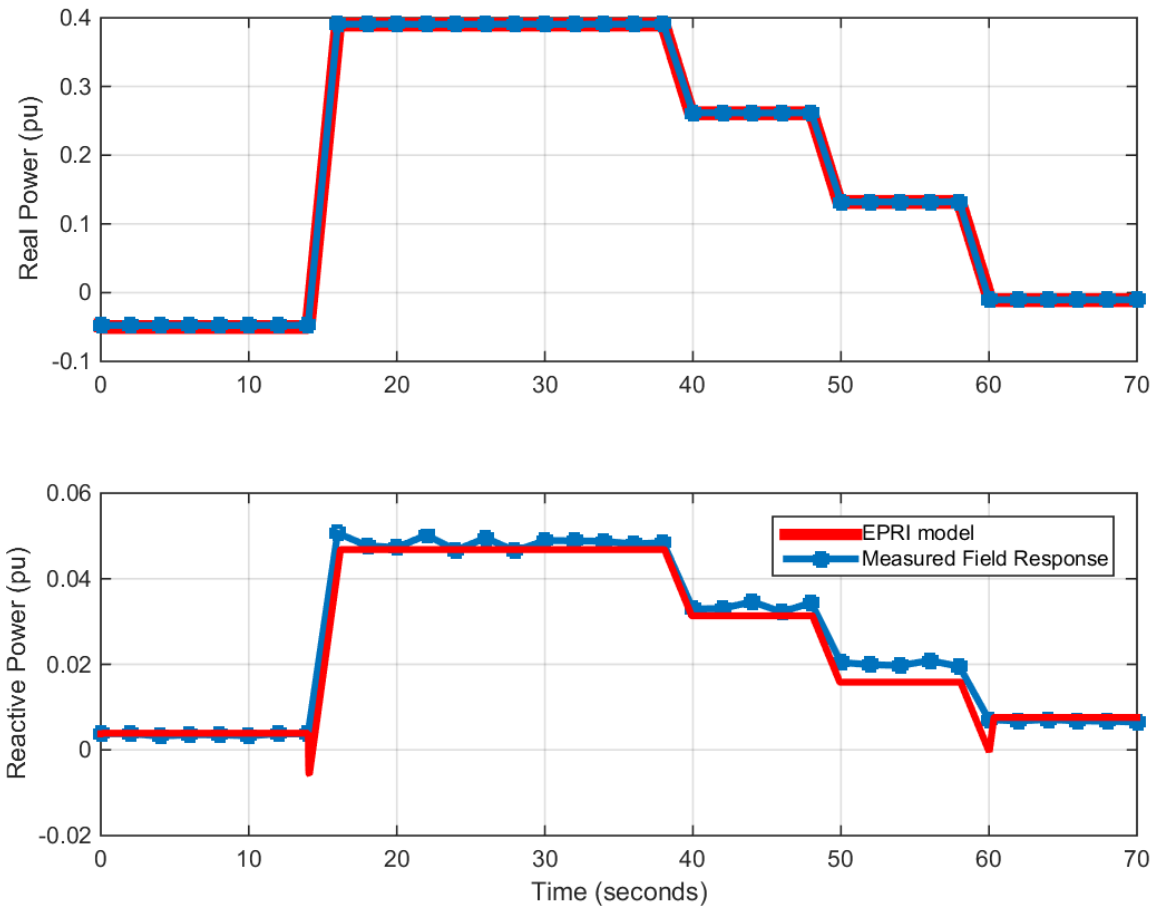

Figure 4: Simulation and measurement of an actual 36 MVA BESS unit’s response to a sequence of Pref changes (device in constant pf control).

Together . . . Shaping the Future of Electricity

Knoxville Office

942 Corridor Park Blvd., Knoxville, TN 37932 USA • 865.218.8000 • Fax 865.218.8001 • Customer Service 800.313.3774 • www.epri.com