



Electric Reliability and Security for the West

WECC Criterion
TPL-001-WECC-CRT-4

Introduction

1. **Title:** Transmission System Planning Performance
2. **Number:** TPL-001-WECC-CRT-4
3. **Purpose:** To facilitate coordinated near-term and long-term transmission planning within the Western Interconnection, and to facilitate the exchange of the associated planning information for normal and abnormal conditions.

This document applies to all transmission planning studies conducted within the Western Interconnection.
4. **Applicability:**
 - 4.1. **Functional Entities:**
 - 4.1.1. Planning Coordinator
 - 4.1.2. Transmission Planner
 - 4.2. Facilities
 - 4.2.1. This document applies to Bulk Electric System (BES) Facilities.
 - 4.2.2. The following buses are specifically *excluded* from this WECC Criterion:
 - 4.2.2.1. Non-BES buses,
 - 4.2.2.2. Line side series capacitor buses,
 - 4.2.2.3. Line side series reactor buses,
 - 4.2.2.4. Dedicated shunt capacitor buses,
 - 4.2.2.5. Dedicated shunt reactor buses,
 - 4.2.2.6. Metering buses, fictitious buses, or other buses that model point of interconnection solely for measuring electrical quantities; and
 - 4.2.2.7. Other buses specifically excluded by each Planning Coordinator or Transmission Planner internal to its system.
5. **Effective Date:** July 1, 2023

TPL-001-WECC-CRT-4—Transmission System Planning Performance

Requirements and Measures

WR1. Each Transmission Planner and Planning Coordinator shall use the following *default* base planning criteria:

- 1.1.** Steady-state voltages at all applicable Bulk-Electric System (BES) buses shall stay within each of the following limits:
 - 1.1.1.** 95 percent to 105 percent of nominal¹ for P0² event (system normal pre-contingency event powerflow).
 - 1.1.2.** 90 percent to 110 percent of nominal for P1-P7 events (post-contingency event powerflow).
 - 1.2.** Post-Contingency steady-state voltage deviation at each applicable BES bus serving load shall not exceed 8 percent for P1 events.
 - 1.3.** Following fault clearing, the voltage shall recover to 80 percent of the pre-contingency voltage within 20 seconds of the initiating event for all P1 through P7 events, for each applicable BES bus serving load. (See Rationale regarding BES bus serving load.)
 - 1.4.** Following fault clearing and voltage recovery above 80 percent, voltage at each applicable BES bus serving load shall neither dip below 70 percent of pre-contingency voltage for more than 30 cycles nor remain below 80 percent of pre-contingency voltage for more than two seconds, for all P1 through P7 Single-Line to Ground fault events.
 - 1.5.** For Contingencies without a fault (P2.1 category event), voltage dips at each applicable BES bus serving load shall neither dip below 70 percent of pre-contingency voltage for more than 30 cycles nor remain below 80 percent of pre-contingency voltage for more than two seconds.
 - 1.6.** All oscillations that do not show positive damping within 30 seconds after the start of the studied event shall be deemed unstable.
- WM1.** Each Transmission Planner and Planning Coordinator will have evidence that it used the base criteria in its planning assessment specified in Requirement WR1.

¹ Refer to the Rationale section for use of the term “nominal.”

² P0 through P7 refers to the categories of contingencies identified in Table 1 of NERC Standard TPL-001-X, Transmission System Planning Performance Requirements, or its successor.



TPL-001-WECC-CRT-4—Transmission System Planning Performance

WR2. Each Transmission Planner and Planning Coordinator shall use the following *default* criteria to identify the potential for Cascading or uncontrolled islanding.

- When a post contingency analysis results in steady-state facility loading that is either more than a known BES facility trip setting, or exceeds 125 percent of the highest seasonal facility rating for the BES facility studied. If the trip setting is known to be different than the 125 percent threshold, the known setting should be used.
- When either unrestrained successive load loss occurs, or unrestrained successive generation loss occurs.

WM2. Each Transmission Planner and Planning Coordinator will have evidence that it used the indicators of Requirement WR2 to identify the potential for Cascading or uncontrolled islanding.

WR3. Each Transmission Planner and Planning Coordinator shall use the following *default* criteria when identifying voltage stability:

- 3.1. For transfer paths, all P0-P1 events shall demonstrate a positive reactive power margin at a minimum of 105 percent of transfer path flow.
- 3.2. For transfer paths, all P2-P7 events shall demonstrate a positive reactive power margin at a minimum of 102.5 percent of transfer path flow.
- 3.3. For load areas, all P0-P1 events shall demonstrate a positive reactive power margin at a minimum of 105 percent of forecasted peak load.
- 3.4. For load areas, all P2-P7 events shall demonstrate a positive reactive power margin at a minimum of 102.5 percent of forecasted peak load.

WM3. Each Transmission Planner and Planning Coordinator will have evidence that it used the minimum criteria identified in Requirement WR3 to identify voltage stability.

WR4. Each Transmission Planner and Planning Coordinator that uses planning criteria *different than the default* planning criteria in WR1, WR2, and WR3 shall:

- 4.1 Document the different criteria to include each of the following:
 - 4.1.1 A narrative explaining why the different criteria was used.
 - 4.1.2 A narrative explaining that the use of the different criteria will not result in violations of equipment ratings, instability, uncontrolled islanding, or Cascading on its own and adjacent systems.
- 4.2 Notify adjacent Transmission Planners and Planning Coordinators that criteria different from WR1 was used.



TPL-001-WECC-CRT-4—Transmission System Planning Performance

4.3 Make the different criteria available within 30 days of a request.

WM4. Each Transmission Planner and Planning Coordinator that uses planning criteria different than the default base planning criteria in WR1, WR2, and WR3 will have evidence documenting the different criteria, a narrative explaining why the different criteria was used, and evidence of public notice and availability of the criteria, as required in WR4.



TPL-001-WECC-CRT-4—Transmission System Planning Performance

Version History

Version	Date	Action	Change Tracking
1	March 6, 2008	WECC Planning Coordination Committee (PCC) approved TPL-(001 thru 004)-WECC-1-CR.	Reliability Subcommittee translates existing WECC components of NERC/WECC Planning Standards into a CRT.
1	April 16, 2008	WECC Board of Directors (Board) approved	No substantive changes
2	October 13, 2011	PCC approves	Clarifies “corridor”
2	December 1, 2011	Board approved	No substantive change
2	September 5, 2012	Board changed designation	Approved a nomenclature change from “CRT” to “RBP”
2.1	August 6, 2013	Errata	WM2 Measure moved to WM3. WM3 Measure moved to WM4. WM4 Measure moved to WM2.
2.1	December 5, 2013	Board approved	Developed as WECC-0100, on October 8, 2013, the Ballot Pool retired WR1, WR2, WR4 and WR5 of TPL-(012 through 014)-WECC-RBP-2 coincident with the October 17, 2015, Effective Date of NERC TPL-001-4, Transmission System Planning Performance requirements. (See 18 CFR Part 40, Docket RM-12-1-000 and RM13-9-000, FERC Order 786, issued October 17, 2013.) Table W-1, WECC Disturbance-Performance Table of Allowable Effects on Other Systems, Table W-1 Notes, Figure W-1, and Footnotes 1-3 were also retired along with their supporting WECC Requirements, WR1, WR2, and WR5. On December 5, 2013, the Board ratified that decision.
2.1	June 25, 2014	Board changed designation	Changed from regional Business Practice (RBP) to Criterion (CRT). No other changes.
2.2	January 14, 2016	Errata	Retired WECC Requirements WR1, WR2, WR4, and WR5 and their subsets were removed from the document. WR3 was renumbered to WR1.
2.3	September 20, 2016	Errata	Sub-parts of the 4.2 Facilities section impacted by the retirement of WR1, WR2, WR4 and WR5 of TPL-(012 through 014)-WECC-RBP-2 were removed.
3	September 21, 2016	Board approved	This document addresses: 1) the substance of its preceding versions, 2) requirements imposed by NERC TPL-001-4, Transmission System Planning Performance Requirements, Requirements R5 and R6, and 3) the substance of Table W-1 retired from Version 2.1. The Effective Date was approved as “the later of January 1, 2016, or the Effective Date of TPL-001-4, Transmission System Planning Performance, Requirements R2-R6 and R8, subject to approvals.” Because the effective date of the NERC requirements has already been triggered the document was effective immediately on approval by the Board.
3.1	December 6, 2016	Errata	The spelling error in Section 4.2.2.6 “quantizies” was corrected to read “quantities.” In WM2, the phrase “the criteria was applied” was replaced with “the criterion was applied.”
3.2	June 18, 2019	Errata	Converted to newest template. In Version 3.2: 1) bulleting in 4.2 Facilities was corrected, 2) at 4.2.2.7, “their” was replaced with “its”, 3) use of “X%” was changed to “X percent” throughout, 4) use of “are/is allowed” was changed to “can” throughout, 5) WR4, “as long as” was replaced with “if”, “in excess” was replaced with “more than”, 6)



TPL-001-WECC-CRT-4—Transmission System Planning Performance

			Version History syntax was corrected, 7) Rationale section, “with the exception of the 500 kilo-volt class” changed to “except the 500 kilo-volt class”, Rationale section (last page) “don’t” was changed to “do not”, 8) Rationale section at WR4, second bullet “Prepared” replaced with “prepared” and at the next to the last paragraph, “time frame” was replaced with “period”.
4	June 14, 2023	Board approved	The following changes were made to Version 4. Purpose: “WECC” replaced with “Western Interconnection”, planning criteria verbiage was deleted. Facilities: “excluded” was italicized, Requirement WR1: “unless otherwise” qualifier was deleted, WR1.3, a reference was added to the Rationale section, WR1.4, “Single-Line to Ground fault” qualifies the specified event, previous WR2 and WR3 deleted, new WR2 italicizes “default”, passive language was deleted, bullet 2 was deleted, new WR3: replaces “minimum” with “default”, new WR4: replaces “study” with “planning”, replaces “base” with “default”, adds a requirement to document and communicate studies. Rationale: WR1 narrative was simplified, WR1.1 and WR1.2 were embellished, WR1.3 and WR1.4 narrative clarifies application to “(FIDVR)”, WR2 deletes reference to “Peak Reliability”, WR3 clarifies the role of the Transmission Planner and Coordinator, WR4 clarifies distinction between “different” and “default”. Footnote 2: “or its successor” was added. Previous footnote 3 deleted as superfluous. Measures and references were updated accordingly.

WECC receives data used in its analyses from a wide variety of sources. WECC strives to source its data from reliable entities and undertakes reasonable efforts to validate the accuracy of the data used. WECC believes the data contained herein and used in its analyses is accurate and reliable. However, WECC disclaims any and all representations, guarantees, warranties, and liability for the information contained herein and any use thereof. Persons who use and rely on the information contained herein do so at their own risk.



TPL-001-WECC-CRT-4—Transmission System Planning Performance

Attachments or Other Reference Material

Though not part of this WECC Criterion, the reader may refer to the following documents for historic background:

- WECC Guide to WECC/NERC Planning Standards 1.D: *Voltage Support and Reactive Power*, prepared by: Reactive Reserve Working Group (RRWG), Under the auspices of Technical Studies Subcommittee (TSS); Approved by TSS, March 30, 2006. Specific emphasis might be focused to Section 2.2 Voltage Stability.
- The applicable Reliability Coordinator’s Systems Operating Limits Methodology.
- White Paper WECC-0100 TPL-001-WECC-CRT-3 (CRT) Transmission System Planning Performance Proposed Transient Voltage Response Rationale for CRT Requirements R1.3 and R1.4”, dated July 24, 2015, augmented by IEEE Standard 1668.
- Voltage Stability Criteria, Undervoltage Load Shedding Strategy, and Reactive Power Reserve Monitoring Methodology”, dated May 1998. The voltage stability criteria recommendation that is the basis for Requirement WR3 was developed under the WECC Reactive Reserve Work Group (RRWG) and documented in the report.

Rationale

General Application

Nothing in this document is to be interpreted as allowing third-party actions to impute liability on another. Each applicable entity is responsible for adherence to this WECC Criterion based solely on its own actions.

A BES bus that is serving load is the bus with direct transformation to a non-BES bus (the non-BES bus may be radial or networked) that serves customer load. Station-service and other substation loads are excluded.

For example, this definition meets the intent of having the criteria apply to BES Buses 3, 8 and 12 but not to BES buses 1, 2, 9, 13, and 14. (See below.)



TPL-001-WECC-CRT-4—Transmission System Planning Performance

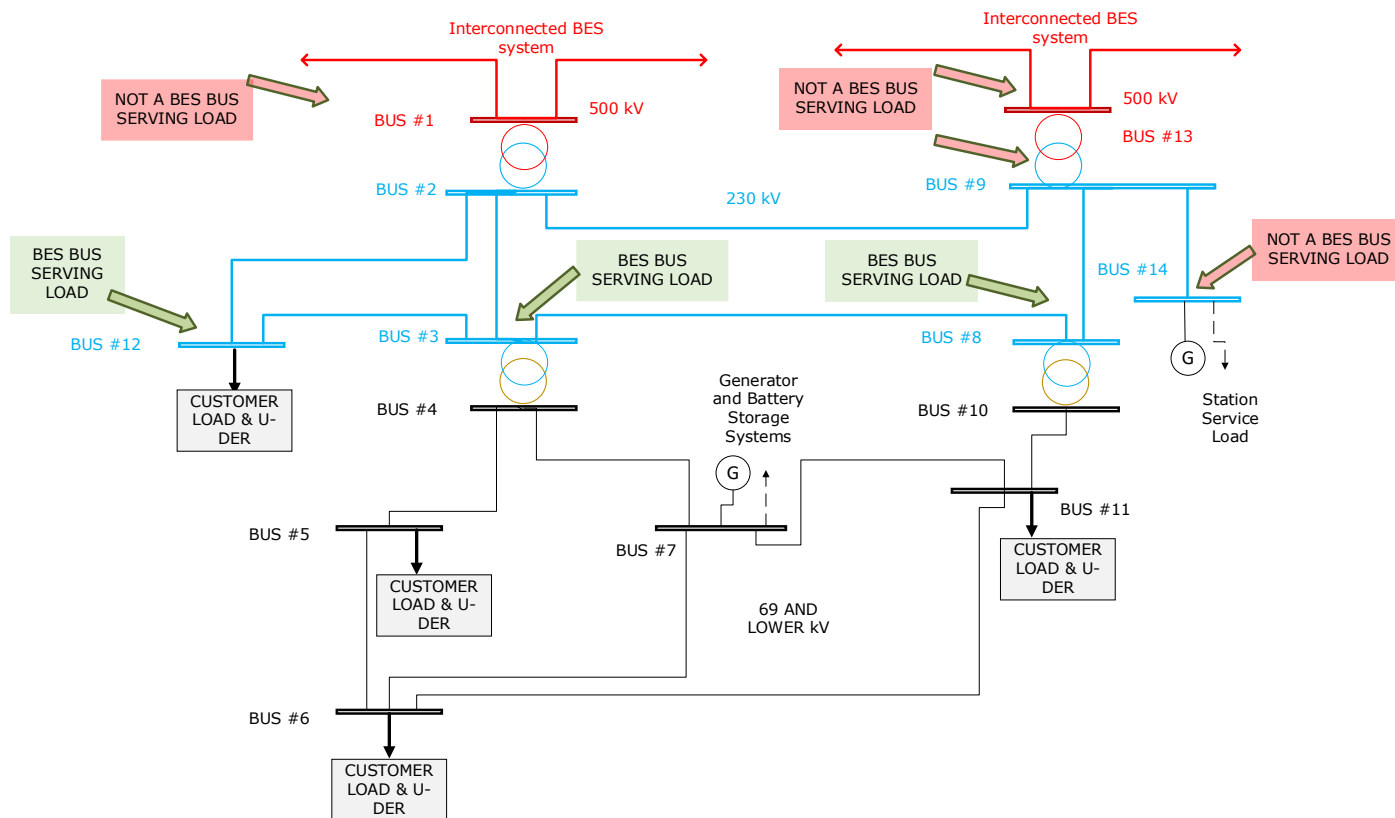

1

Requirement WR1

WR1 is designed to state the default base planning criteria the system must meet. WR1 does not prohibit the use of more stringent criteria; rather, it sets the minimum threshold. See WR4.

In the context of Requirement WR1, the word “nominal” carries its common definition and could be, for example, either the base voltage or the operating voltage as established in the entity’s Planning Assessment. This means that nominal may have a varying definition or use from one entity to the next.

An entity has the option to specify its nominal voltage different from 525 kV for the 500-kV system.

If an entity does not specify what is nominal, the default use of the term nominal defaults to the kilovolt class that is specified in the WECC Base Case, except the 500-kilovolt class, in which case the default nominal would be specified as 525 kilovolts.

Requirement WR1.1 and WR1.2

WR1.1 describes the ceiling and floor of the *magnitude* of voltage allowed at any of the applicable BES buses both under normal operating conditions and after a P1 event (and other P events). WR1.2 describes the *change* in voltage that is allowed between pre/post P1 events. WR1.1 and WR1.2 are independent of one another; one does not guarantee the other thus requiring two sets of criteria.



TPL-001-WECC-CRT-4—Transmission System Planning Performance

For instance,

- a) A BES bus at 0.95 p.u. pre-contingency voltage may encounter a contingency that drops the voltage to 0.88 p.u. => would violate WR1.1.2 (<0.9 p.u.) but not WR1.2 (<8% drop).
- b) Another BES bus at 1.05 p.u. pre-contingency encounters a contingency that drops the voltage to 0.92 p.u. => would violate WR1.2 (> 8%) but not WR1.1.2 (>0.9 p.u.).”

Requirement WR1.1.2 refers to the post-automatic equipment adjustment effect prior to manual adjustment.

Requirement WR1.2

In developing WR1.2, the drafting team was aware that eight percent is not the only practical percentage for use. Historically, stakeholders reported successfully using percentages between five and ten whereas others reported being under a regulatory mandate to use eight percent. To accommodate both positions the team selected the eight percent.

By default, only automatic post-contingency actions occurring in the studied timeframe are considered when calculating voltage deviation. This would include, among other things, capacitor or reactor switching. For purposes of WR1.2, automatic generally means a programmed response not manually initiated.

For P2-P7, there is no low or high voltage deviation requirement. It is implied that P2 through P7 events do not require a voltage deviation beyond meeting the requirements in WR1.1.2.

Requirement WR1.3 and WR1.4

WR1.3 is intended to identify potential Fault-Induced Delayed Voltage Recovery (FIDVR) events (See Illustration WR1.3). This differentiates WR1.3 from WR1.4.

Illustrations WR1.3 and WR1.4 are illustrative only and are not intended to depict all possible voltage trajectories.

WR1.4 is intended to describe normal voltage recovery and is not designed to address FIDVR (see Illustration WR1.4). There are no voltage performance criteria in WR1.4 for P1 through P7, Three-Phase Fault events.

TPL-001-WECC-CRT-4—Transmission System Planning Performance

Requirement WR2

Requirement WR2 is designed to establish screening criteria that when exceeded may require further investigation of instability. The Requirement is not intended to show the presence of Cascading or instability.

The term Cascading in WR2 is the NERC defined term.

In WR2 Bullet 1, the 125 percent threshold should only be used for facilities where the trip setting is not known.³ If the trip setting is known than known settings should be used. For example, if the known trip setting is 150 percent of the continuous rating, this should take precedence over the 125 percent of the highest rating.

The specific amounts of unrestrained load loss addressed in WR2, Bullet 2 are not specified in this document. Because of the breadth of the possible permutations, the amount should be left to the sound engineering judgment of the planning entity.

Requirement WR3

The intent of Requirement WR3 is to ensure the voltage stability of transfer paths as well as the system as a whole during peak load or peak transfer conditions. A margin on real power flow is used as a test for voltage stability. A positive reactive power margin can be demonstrated by a valid steady state power flow solution.

WR3 acknowledges that the Transmission Planner and Planning Coordinator are in the best position to self-determine which transfer paths and load areas are most critical for study.

WR3 does not require studying each transfer path and load area, nor does it supersede NERC transmission system planning performance requirements addressing the criteria or methodology used to identify system instability.

Power flow solutions refer to post contingency conditions where the actions of reactive devices and load tap changers should be studied for the appropriate period being studied.

There is a higher likelihood of occurrence of a P0 to P1 category event; therefore, a higher margin (105%) is used. For P2–P7, there is a lower likelihood of occurrence; therefore, the lower margin (102.5%) is used.

Requirement WR4

WR4 does not change the WR1, WR2, and WR3 defaults; rather, WR4 allows for a different approach without changing the defaults.

³ The values in WR2 have their historic roots in the Peak Reliability Coordinator Systems Operating Limits Methodology.



TPL-001-WECC-CRT-4—Transmission System Planning Performance

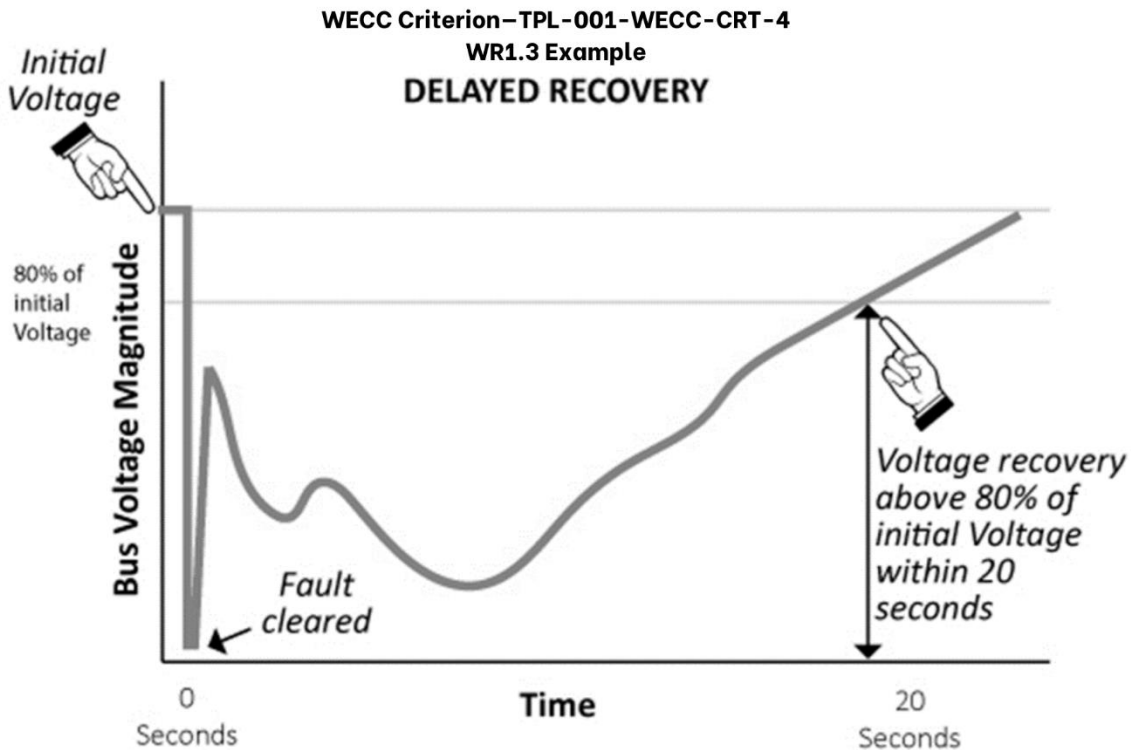

TPL-001-WECC-CRT-4—Transmission System Planning Performance

WECC Criterion—TPL-001-WECC-CRT-4

WR1.4 Example

NORMAL RECOVERY 1

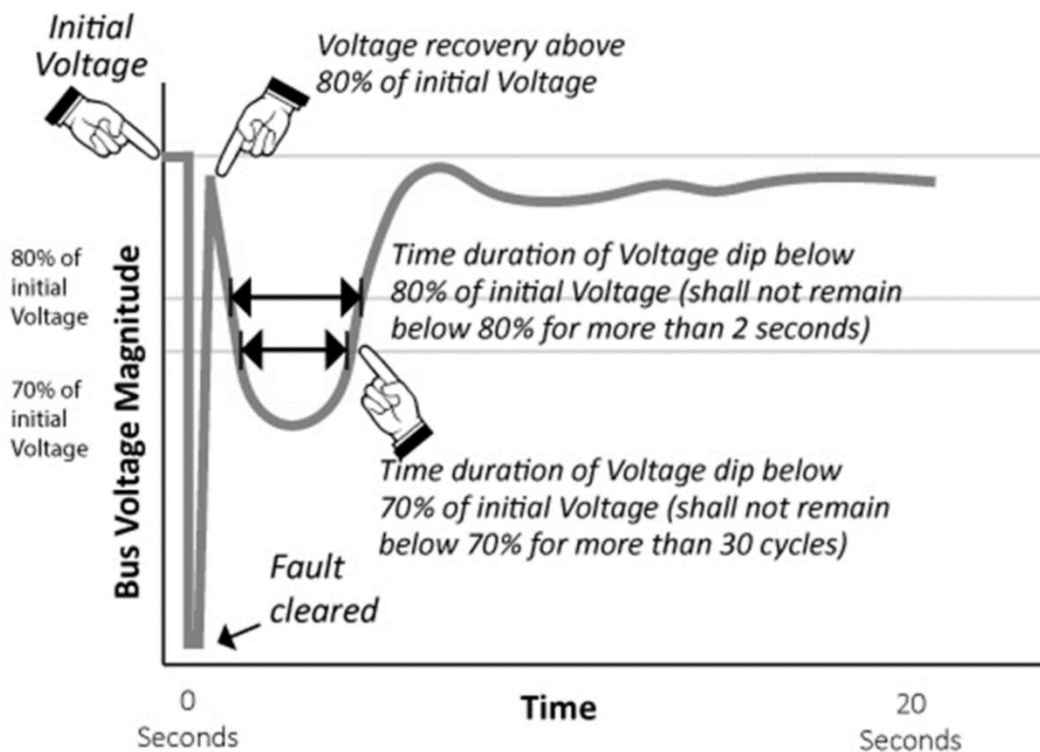

TPL-001-WECC-CRT-4—Transmission System Planning Performance

WECC Criterion—TPL-001-WECC-CRT-4

WR1.4 Example

NORMAL RECOVERY 2

